

HSF

NOTES:

- Current Rating: 1.0AMP.(20°C,1*2P-1*15P)
0.75AMP.(20°C,1*16P-1*50P)
- Contact Resistance: 20mΩ max
- Withstand Voltage: 500V AC
- Insulation Resistance: 1000MΩ min
- Operation Temperature: -40°C to +125°C(Gold Plating)
-40°C to +105°C(Tin Plating)
- Contact Material: Copper alloy
- Housing Material: PA9T(UL94V-0),Black
- Contact plating: Au Or Sn Over 30u" Min Ni
- Post type: have post or no post

Ordering Information

2537-1 XX Z XX C U N X X

- Plastic Row
- No. of Pins Per Row: 02-50
- Welding Type Z=R/A&SMT
- Contact Plating G0=Gold Flash G3=10u"Au, BG3=8u"PdNi+2u"Au G4=15u"Au, BG4=13u"PdNi+2u"Au G5=30u"Au, BG5=28u"PdNi+2u"Au S0=Gold Flash/Tin S3=10u"Au/Sn, P3=8u"PdNi+2u"Au/Sn S4=15u"Au/Sn, P4=13u"PdNi+2u"Au/Sn S5=30u"Au/Sn, P5=28u"PdNi+2u"Au/Sn SN=Bright Tin SM=Matte Tin
- Packing: T=Tube R=Tape&Reel
- Logo N=W/O Logo
- Contact Type U=U Type
- Insulator Material C=PA9T

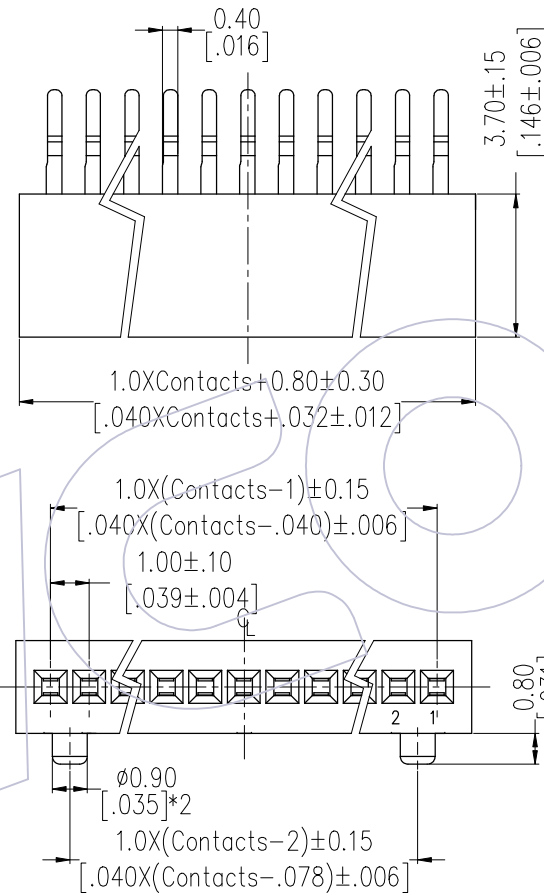

Recommended P.C.B Layout(Top Side)
 (PCB BOARD TOLERANCE±0.05)
 (PCB Thickness: T=1.60mm)

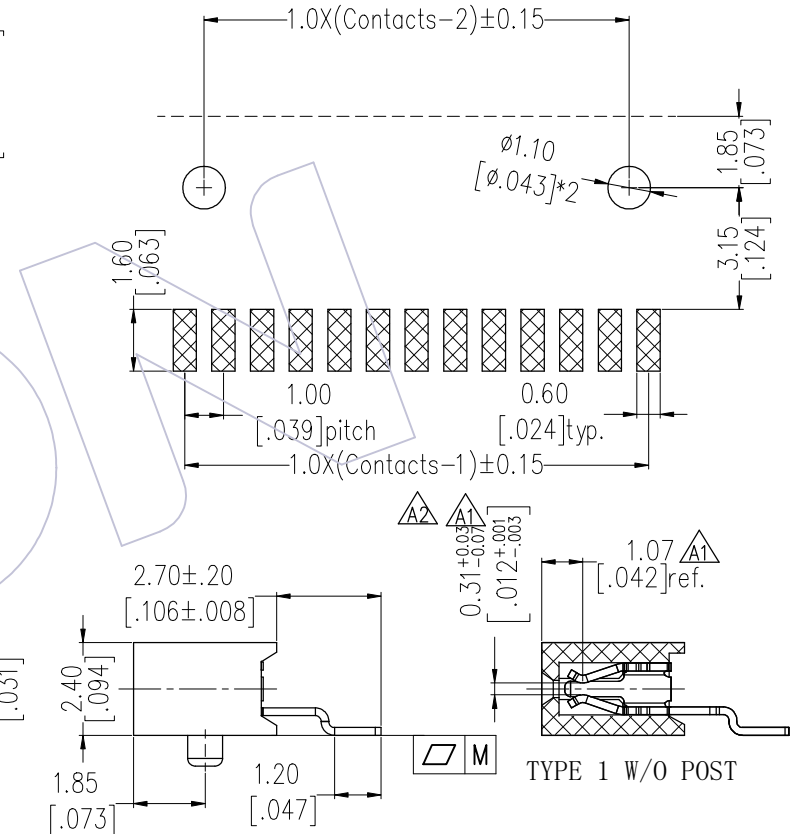

Item	Pitch	Mating	DIM.B
Standard	1.00	1537	1.90
Alternate			

Pin(Per Row)	2-15P	16-30P	31-40P
M	0.10	0.12	0.18

TITLE	PART NO.
TYPE 1	2537-1XXZXXCUNT1
TYPE 2	2537-1XXZXXCUNT2

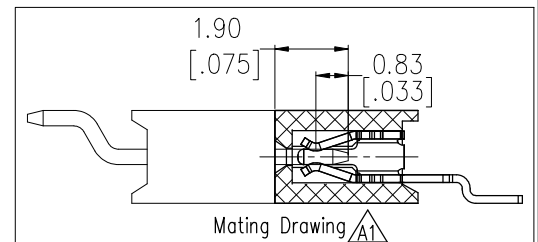

REV	DATE	MODIFICATION DESCRIPTION	CHANGE	OPERATION	DRAW	DATE	SCALE	PART NO.
A2	2026/01/16	Standardization Drawing	CP	X.X ±0.40	CP	2026/01/16	1:1	2537-1XXZXXCUNT X
A1	2023/02/03	Add Flatness	XSR	X.XX ±0.25	CHECK	2026/01/16	mm	TITLE: 1.00mm Female Header SINGLE ROW 90°SMT H=3.7
A0	2013/06/26	NEW	Wang	X.XXX ±0.15	TANG	2026/01/16	A4	Customer NO.
				Angle ± 3°	APPROVE	2026/01/16	1/3	
				DIM TOL	Steven Zhao		PROJ.	

WCON
 Http: www.wcon.com

WCON-Dongguan
 Tel: +86 769 85358920
 Fax: +86 769 85358915
 E-mail: sales@wcon.com

WCON-Kunshan
 Tel: +86 512 57468408
 Fax: +86 512 57468468
 E-mail: wconks@wcon.com

HSF

Packing:

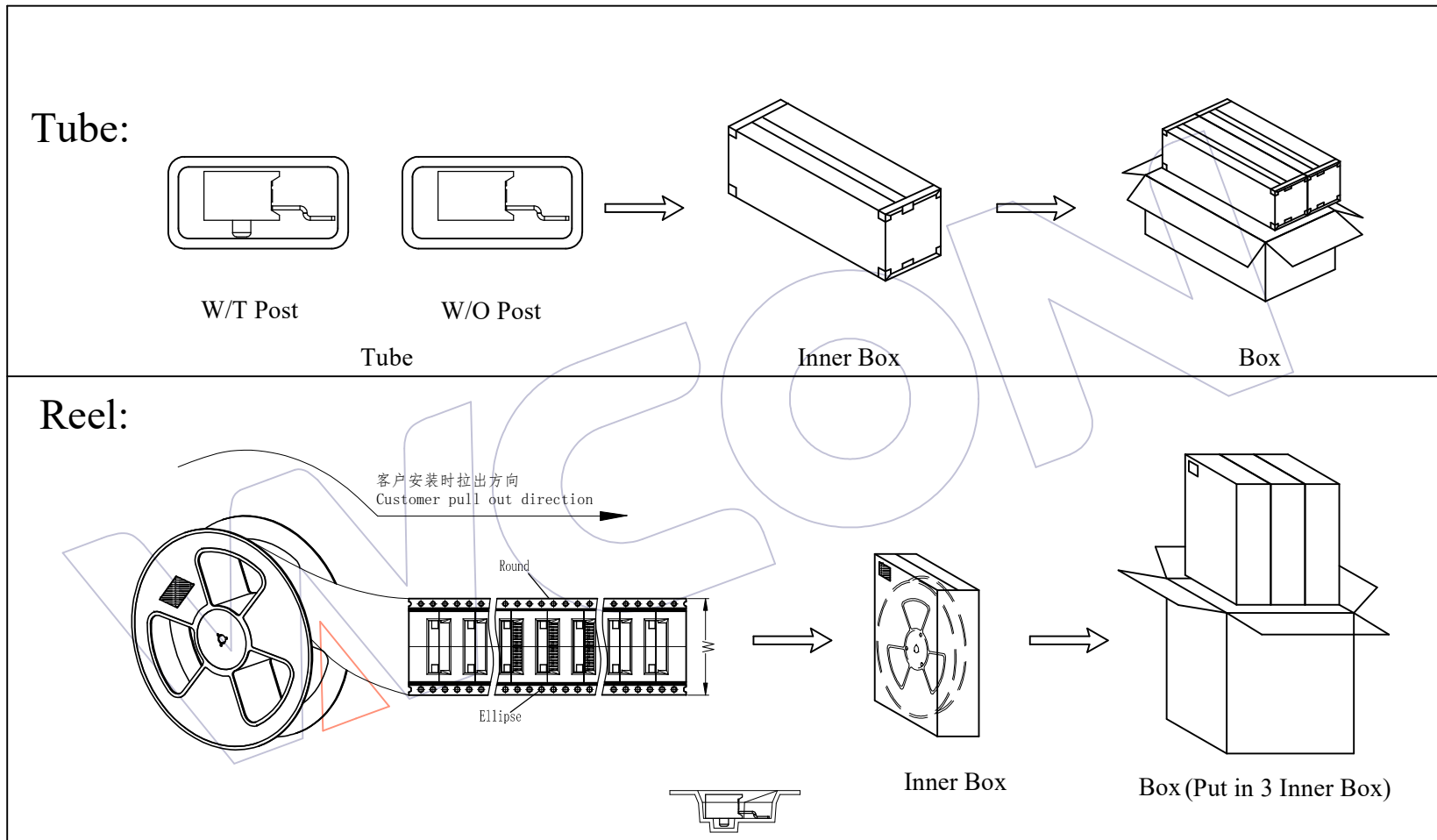

				OPERATION		DRAW	DATE	SCALE	1:1	PART NO.		 Http: www.wcon.com WCON-Dongguan Tel: +86 769 85358920 Fax: +86 769 85358915 E-mail: sales@wcon.com	WCON-Kunshan Tel: +86 512 57468408 Fax: +86 512 57468468 E-mail: wconks@wcon.com
A2	2026/01/16	Standardization Drawing	CP	X.X	±0.40	CP	2026/01/16	UNIT	mm	2537-1XXZXXCUNT			
A1	2023/02/03	Add Flatness	XSR	X.XX	±0.25	CHECK	DATE	SIZE	A4	TITLE:			
A0	2013/06/26	NEW	Wang	X.XXX	±0.15	TANG	2026/01/16	SHEET	2/3	1.00mm Female Header SINGLE ROW 90°SMT H=3.7			
REV	DATE	MODIFICATION DESCRIPTION	CHANGE	Angle	± 3'	APPROVE	DATE	PROJ.	⚙️	Customer NO.			
				DIM	TOL	Steven Zhao	2026/01/16						

HSF

Packaging Quantity Refers To The Following Table

PINS	Q' ty/Tube	Q' ty/Inner Box	Q' ty/Box
2	1,000/Tray		48,000
3	800/Tray		38,400
4	120	43,200	86,400
5	100	36,000	72,000
6	85	30,600	61,200
7	74	26,640	53,280
8	65	23,400	46,800
9	59	21,240	42,480
10	53	19,080	38,160
11	49	17,640	35,280
12	45	16,200	32,400
13	42	15,120	30,240
14	39	14,040	28,080
15	36	12,960	25,920
16	34	12,240	24,480
17	32	11,520	23,040
18	30	10,800	21,600
19	29	10,440	20,880
20	27	9,720	19,440
21	26	9,360	18,720
22	25	9,000	18,000
23	24	8,640	17,280
24	23	8,280	16,560
25	22	7,920	15,840
26	21	7,560	15,120

PINS	Q' ty/Tube	Q' ty/Inner Box	Q' ty/Box
27	20	7,200	14,400
28	20	7,200	14,400
29	19	6,840	13,680
30	18	6,480	12,960
31	18	6,480	12,960
32	17	6,120	12,240
33	17	6,120	12,240
34	16	5,760	11,520
35	16	5,760	11,520
36	15	5,400	10,800
37	15	5,400	10,800
38	14	5,040	10,080
39	14	5,040	10,080
40	14	5,040	10,080
41	13	4,680	9,360
42	13	4,680	9,360
43	13	4,680	9,360
44	12	4,320	8,640
45	12	4,320	8,640
46	12	4,320	8,640
47	12	4,320	8,640
48	11	3,960	7,920
49	11	3,960	7,920
50	11	3,960	7,920

PINS	W	Q' ty/Reel	Q' ty/Inner Box	Q' ty/Box
2	12	1,300	7,800	23,400
3	12	1,300	7,800	23,400
4	16	1,300	5,200	15,600
5	16	1,300	5,200	15,600
6	16	1,300	5,200	15,600
7	16	1,300	5,200	15,600
8	24	1,300	3,900	11,700
9	24	1,300	3,900	11,700
10	24	1,300	3,900	11,700
11	24	1,300	3,900	11,700
12	24	1,300	3,900	11,700
13	24	1,300	3,900	11,700
14	24	1,300	3,900	11,700
15	24	1,300	3,900	11,700
16	32	1,300	2,600	7,800
17	32	1,300	2,600	7,800
18	32	1,300	2,600	7,800
19	32	1,300	2,600	7,800
20	32	1,300	2,600	7,800
21	44	1,300	2,600	7,800
22	44	1,300	2,600	7,800
23	44	1,300	2,600	7,800
24	44	1,300	2,600	7,800
25	44	1,300	2,600	7,800
26	44	1,300	2,600	7,800

PINS	W	Q' ty/Reel	Q' ty/Inner Box	Q' ty/Box
27	44	1,300	2,600	7,800
28	44	1,300	2,600	7,800
29	44	1,300	2,600	7,800
30	44	1,300	2,600	7,800
31	44	1,300	2,600	7,800
32	44	1,300	2,600	7,800
33	56	1,300	1,300	3,900
34	56	1,300	1,300	3,900
35	56	1,300	1,300	3,900
36	56	1,300	1,300	3,900
37	56	1,300	1,300	3,900
38	56	1,300	1,300	3,900
39	56	1,300	1,300	3,900
40	56	1,300	1,300	3,900
41	56	1,300	1,300	3,900
42	56	1,300	1,300	3,900
43	56	1,300	1,300	3,900
44	56	1,300	1,300	3,900
45	72	1,300	1,300	3,900
46	72	1,300	1,300	3,900
47	72	1,300	1,300	3,900
48	72	1,300	1,300	3,900
49	72	1,300	1,300	3,900
50	72	1,300	1,300	3,900

REV	DATE	MODIFICATION DESCRIPTION	CHANGE	OPERATION	DRAW	DATE	SCALE	1:1	PART NO.
A2	2026/01/16	Standardization Drawing	CP	X.X ±0.40	CP	2026/01/16	UNIT	mm	2537-1XXZXCUNT
A1	2023/02/03	Add Flatness	XSR	X.XX ±0.25	CHECK	2026/01/16	SIZE	A4	TITLE:
A0	2013/06/26	NEW	Wang	X.XXX ±0.15	TANG		SHEET	3/3	1.00mm Female Header SINGLE ROW 90°SMT H=3.7
				Angle ± 3°	APPROVE	DATE	PROJ.		Customer NO.
				DIM TOL	Steven Zhao	2026/01/16			



WCON-Dongguan Tel: +86 769 85358920 Fax: +86 769 85358915 E-mail: sales@wcon.com	WCON-Kunshan Tel: +86 512 57468408 Fax: +86 512 57468468 E-mail: wconks@wcon.com
---	---