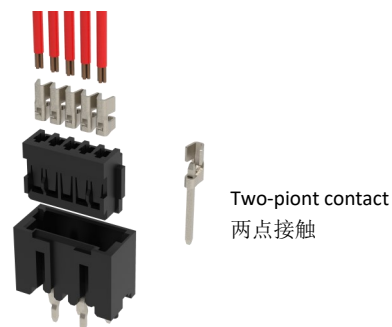
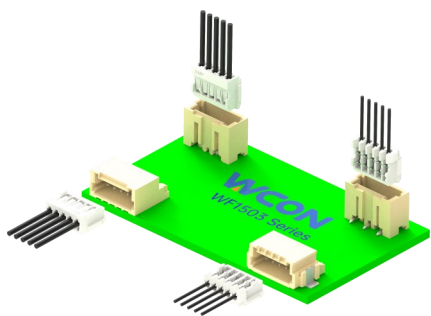

WF1503 Series WF1503系列

1.50mm pitch/Wire-to-board Connector 1.50mm间距/线到板连接器

**Overview**

WF1503 is a 1.50mm pitch wire to board connector, the product has both high density, high performance, high integration and other advantages, can effectively ensure the stability of the signal transmission and integrity, the board end to provide horizontal and vertical direction of the board mounting, to meet the customer's different angles of the insertion of the adapter.

Features and Benefits

- Small size and high integration
- Mis-insertion-proof design to avoid mis-insertion effectively
- Double-contact design of wire terminals, effectively ensure the stability of male and female terminals
- Crimp and IDC two kinds of termination options

Product Applications

- Industrial control and automation
- Computer and Interface Devices
- Telecommunication Modules

Standard 标准

- IEC 60512

Material 材料

Part/零件	Material/材料	Finish/电镀	UL Flame retardant/阻燃等级
Housing/主体	PA66	Black/黑色 Beige/米黄色 White/白色	UL94V-0
Header/板端	PA9T	Natural/本色	UL94V-0
Terminal/端子	phosphor bronze 磷铜 (C5191)	Tin plated 镀锡	-

概述

WF1503是一款1.50mm间距线到板连接器，产品兼具高密度、高性能，高集成等优点，能有效确保信号传输的稳定性以及完整性，板端提供水平及垂直方向贴板安装，满足客户不同角度对插适配。

产品特点

- 产品体积小，集成度高
- 防错插设计、有效避免错插
- 打线端子双触点设计，有效确保公母端子适配稳定
- 有压接和刺破两种端接方式选择

应用领域

- 工业控制与自动化
- 计算机及接口设备
- 电信通讯模块

Production Specifications 产品规格

Current rating 额定电流	1.0 A	Operating Temperature Range:-25° C~+85° (including temperature rise) Operating Humidity Range:20-80% 工作温度范围: -25° C~+85° C(含温升) 工作湿度范围: ≤80%	Storage Teroerature: Operating Humidity: 储存温度: 25±5° C 储存湿度: ≤60%
Voltage rating 额定电压	100V		

Item 项目	Condition 条件	Specification 规格
Insulation Resistance 绝缘电阻	Measured at 500V DC for 1 minute 测试电压: 500V DC/1分钟	No less than 500M Ω 不少于500MΩ
Withstanding voltage 耐电压	Measured at 500V AC for 1 minute 测试电压: 500V AC/1分钟	No breakdown, no discharge, leakage current <0.5mA 无击穿、无放电、漏电流<0.5mA
Contact Resistance 接触电阻	Measured at 1mA and no higher than 20mV 用20 mV DC进行测量	Contact resistance: Initial value/ 20 mo max After environmental tests/ 30 mo max. 接触电阻: 初始值 20 mΩ 以下 测试后 30 mΩ 以下
Vibration Resistance 抗振动	Frequency : 50 ~ 2000 Hz PSD value : 5.35 Gms minimum Duration : 15 minutes/axis Times : Each of three mutually perpendicular planes. 频率: 50 ~ 2000 Hz PSD值: 5.35 Gms 时长: 15分钟/轴 次数: 3次	No electrical discontinuity of 1μsorgreater 试验过程中未发生1μs瞬断现象, 且外观无损伤, 电气性能正常
Humidity (Steady state) 湿度	Temperature : 25~65°C Humidity: 90 ~95% (R.H) Duration : 96 hours 温度: 25~65° C 湿度: 90 ~95% (R.H) 时间: 96小时	Contact resistance: Initial value/ 20 mo max After environmental tests/ 30 mo max. 接触电阻: 初始值 20 mΩ 以下 测试后 30 mΩ 以下
Salt Spray 盐雾	Temperature:35#2°C Humidity:95~98%(R.H) PHValue : 6.5 ~ 7.2 Duration : 12hours 温度: 35±2° C 湿度: 95~98%(R.H) PH值: 6.5~7.2 时间: 12小时	Contact resistance: Initial value/ 20 mo max After environmental tests/ 30 mo max. 接触电阻: 初始值 20 mΩ 以下 测试后 30 mΩ 以下
Durability(Mating/un-mating) 插拔寿命	30 cycles 循环30次	Contact resistance: Initial value/ 20 mo max After environmental tests/ 30 mo max. 接触电阻: 初始值 20 mΩ 以下 测试后 30 mΩ 以下

PCB Layout 印刷电路板布局

Through-hole type 通孔型

(S/T DIP、R/A DIP)

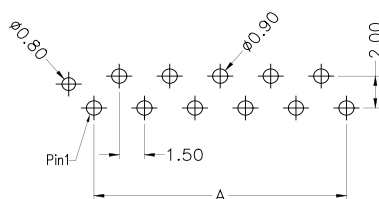

SMT type 表面贴装型

S/T SMT

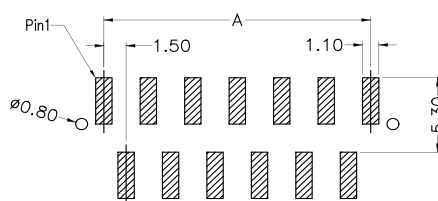

R/A SMT

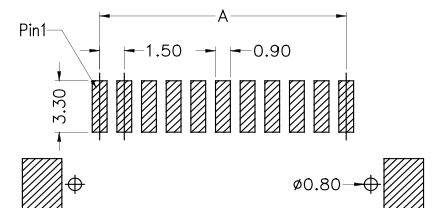

WF1503 Series

Ordering Information 订购信息

Circuit 芯数	Part number 型号		Dimensions 尺寸 (mm)			Parkage 包装 Q'ty/Tube 只/管装		Remake 可量产状态	
	S/T DIP	R/A DIP	A	B	C	S/T DIP	R/A DIP	S/T DIP	R/A DIP
2	WF1503-WS02E01	WF1503-WR02E01	1.50	3.60	5.50	105	105	*	
3	WF1503-WS03E01	WF1503-WR03E01	3.00	5.10	7.00	82	82	*	
4	WF1503-WS04E01	WF1503-WR04E01	4.50	6.60	8.50	68	68	*	
5	WF1503-WS05E01	WF1503-WR05E01	6.00	8.10	10.00	58	58	*	
6	WF1503-WS06E01	WF1503-WR06E01	7.50	9.60	11.50	50	50	*	*
7	WF1503-WS07E01	WF1503-WR07E01	9.00	11.10	13.00	44	44	*	
8	WF1503-WS08E01	WF1503-WR08E01	10.50	12.60	14.50	40	40	*	
9	WF1503-WS09E01	WF1503-WR09E01	12.00	14.10	16.00	36	36	*	
10	WF1503-WS10E01	WF1503-WR10E01	13.50	15.60	17.50	33	33	*	
11	WF1503-WS11E01	WF1503-WR11E01	15.00	17.10	19.00	30	30	*	
12	WF1503-WS12E01	WF1503-WR12E01	16.50	18.60	20.50	28	28	*	
13	WF1503-WS13E01	WF1503-WR13E01	18.00	20.10	22.00	26	26	*	
14	WF1503-WS14E01	WF1503-WR14E01	19.50	21.60	23.50	24	24	*	
15	WF1503-WS15E01	WF1503-WR15E01	21.00	23.10	25.00	23	23	*	
16	WF1503-WS16E01	WF1503-WR16E01	22.50	24.60	26.50	21	21		
17	WF1503-WS17E01	WF1503-WR17E01	24.00	26.10	28.00	20	20		
18	WF1503-WS18E01	WF1503-WR18E01	25.50	27.60	29.50	19	19		
19	WF1503-WS19E01	WF1503-WR19E01	27.00	29.10	31.00	18	18		
20	WF1503-WS20E01	WF1503-WR20E01	28.50	30.60	33.50	18	18		

Note: * stands for mass production. 注: *代表可量产

Dimensions 尺寸 (S/T DIP)

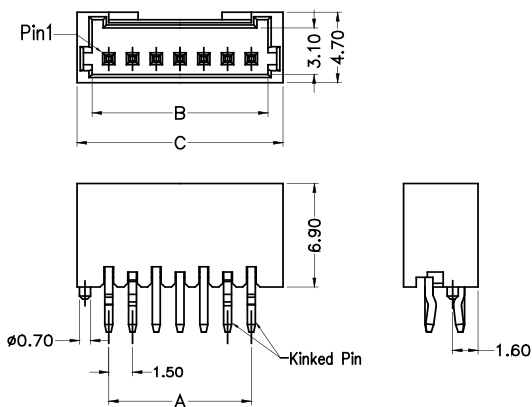

Dimensions 尺寸 (R/A DIP)

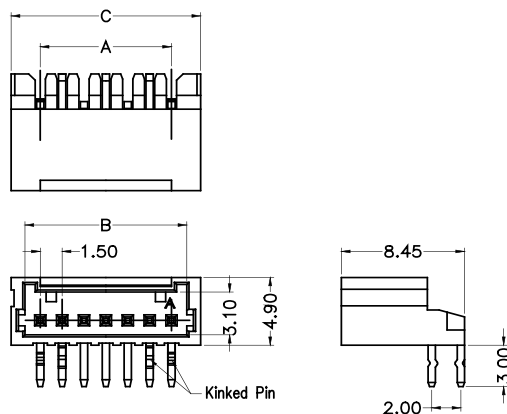

Assembly Schematic 装配示意

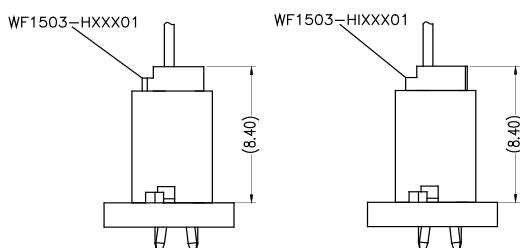

Assembly Schematic 装配示意

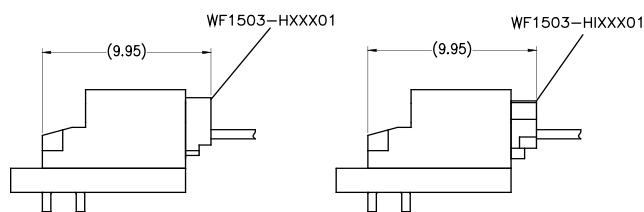

Dimensions 尺寸 (S/T SMT)

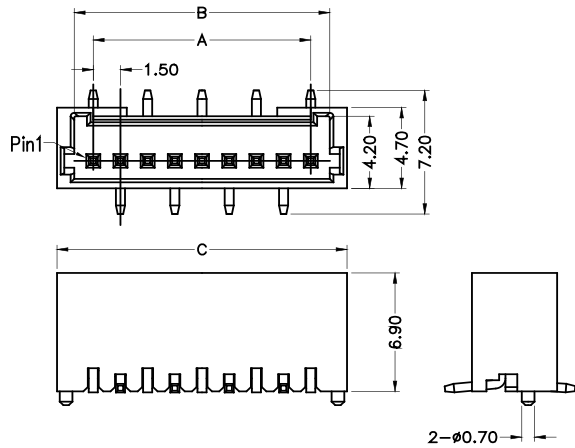

Assembly Schematic 装配示意

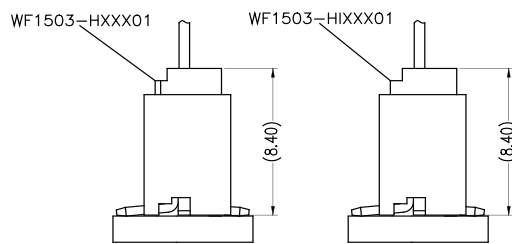

Ordering Information 订购信息

Circuit 芯数	Part number 型号	Dimensions 尺寸 (mm)			Parkage 包装 Q'ty/Reel 只/卷装	Remake 可量产状态
		A	B	C		
2	WF1501-WM02ER1	1.50	3.60	5.50	650	*
3	WF1501-WM03ER1	3.00	5.10	7.00	650	*
4	WF1501-WM04ER1	4.50	6.60	8.50	650	*
5	WF1501-WM05ER1	6.00	8.10	10.00	650	*
6	WF1501-WM06ER1	7.50	9.60	11.50	650	*
7	WF1501-WM07ER1	9.00	11.10	13.00	650	*
8	WF1501-WM08ER1	10.50	12.60	14.50	650	*
9	WF1501-WM09ER1	12.00	14.10	16.00	650	*
10	WF1501-WM10ER1	13.50	15.60	17.50	650	*
11	WF1501-WM11ER1	15.00	17.10	19.00	650	*
12	WF1501-WM12ER1	16.50	18.60	20.50	650	*
13	WF1501-WM13ER1	18.00	20.10	22.00	650	*
14	WF1501-WM14ER1	19.50	21.60	23.50	650	*
15	WF1501-WM15ER1	21.00	23.10	25.00	650	*
16	WF1501-WM16ER1	22.50	24.60	26.50	650	
17	WF1501-WM17ER1	24.00	26.10	28.00	650	
18	WF1501-WM18ER1	25.50	27.60	29.50	650	
19	WF1501-WM19ER1	27.00	29.10	31.00	650	
20	WF1501-WM20ER1	28.50	30.60	32.50	650	

Note: * stands for mass production . 注: *代表可量产

Dimensions 尺寸 (R/A SMT)

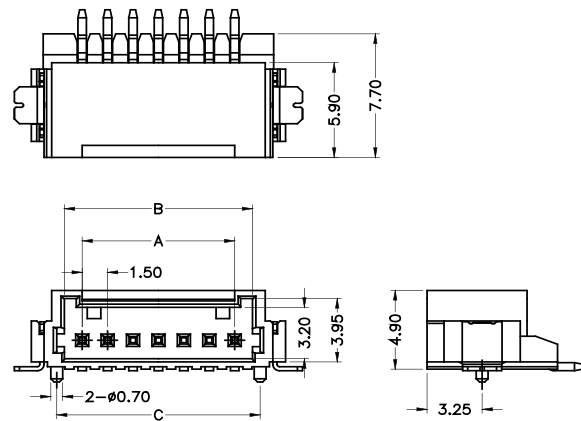

Assembly Schematic 装配示意

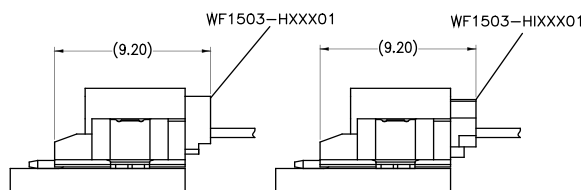

Ordering Information 订购信息

Circuit 芯数	Part number 型号	Dimensions 尺寸 (mm)			Parkage 包装 Q'ty/Reel 只/卷装	Remake 可量产状态
		A	B	C		
2	WF1501-WZ02ER1	1.50	3.60	4.50	900	*
3	WF1501-WZ03ER1	3.00	5.10	6.00	900	*
4	WF1501-WZ04ER1	4.50	6.60	7.50	900	*
5	WF1501-WZ05ER1	6.00	8.10	9.00	900	*
6	WF1501-WZ06ER1	7.50	9.60	10.50	900	*
7	WF1501-WZ07ER1	9.00	11.10	12.00	900	*
8	WF1501-WZ08ER1	10.50	12.60	13.50	900	*
9	WF1501-WZ09ER1	12.00	14.10	15.00	900	*
10	WF1501-WZ10ER1	13.50	15.60	16.50	900	*
11	WF1501-WZ11ER1	15.00	17.10	18.00	900	*
12	WF1501-WZ12ER1	16.50	18.60	19.50	900	*
13	WF1501-WZ13ER1	18.00	20.10	21.00	900	*
14	WF1501-WZ14ER1	19.50	21.60	22.50	900	*
15	WF1501-WZ15ER1	21.00	23.10	24.00	900	*
16	WF1501-WZ16ER1	22.50	24.60	25.50	900	
17	WF1501-WZ17ER1	24.00	26.10	27.00	900	
18	WF1501-WZ18ER1	25.50	27.60	28.50	900	
19	WF1501-WZ19ER1	27.00	29.10	30.00	900	
20	WF1501-WZ20ER1	28.50	30.60	31.50	900	

Note: * stands for mass production . 注: *代表可量产

WF1503 Series

Dimensions 尺寸

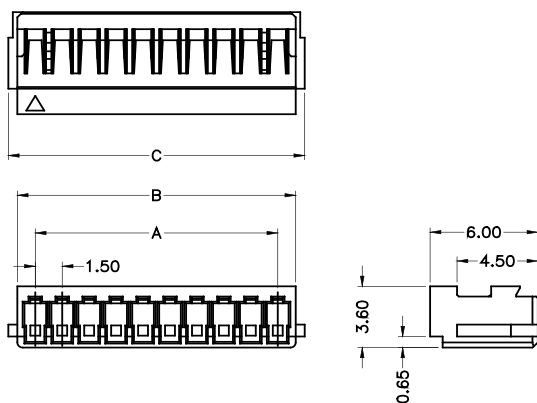

Adaptor Terminal 适配端子

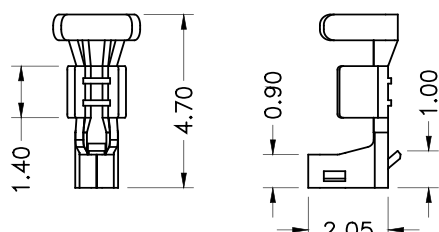

型号 Model number	WF1503-TPSN01
--------------------	---------------

Ordering Information 订购信息

Circuit 芯数	Part number 型号	Dimensions 尺寸 (mm)			Package 包装 Qty/Bag 只/袋装	Remake 可量产状态
		A	B	C		
2	WF1503-H02W01	1.50	3.50	4.50	1000	*
3	WF1503-H03W01	3.00	5.00	6.00	1000	*
4	WF1503-H04W01	4.50	6.50	7.50	1000	*
5	WF1503-H05W01	6.00	8.00	9.00	1000	*
6	WF1503-H06W01	7.50	9.50	10.50	1000	*
7	WF1503-H07W01	9.00	11.00	12.00	1000	*
8	WF1503-H08W01	10.50	12.50	13.50	1000	*
9	WF1503-H09W01	12.00	14.00	15.00	1000	*
10	WF1503-H10W01	13.50	15.50	16.50	1000	*
11	WF1503-H11W01	15.00	17.00	18.00	1000	*
12	WF1503-H12W01	16.50	18.50	19.50	1000	*
13	WF1503-H13W01	18.00	20.00	21.00	1000	*
14	WF1503-H14W01	19.50	21.50	22.50	1000	*
15	WF1503-H15W01	21.00	23.00	24.00	1000	*
16	WF1503-H16W01	22.50	24.50	25.50	1000	*
17	WF1503-H17W01	24.00	26.00	27.00	1000	*
18	WF1503-H18W01	25.50	27.50	28.50	1000	*
19	WF1503-H19W01	27.00	29.00	30.00	1000	*
20	WF1503-H20W01	28.50	30.50	31.50	1000	*

Note: * stands for mass production . 注: *代表可量产

Terminal Crimp specification 端子压接规范

型号 Model number	电线类型 Wire type	电线规格 Wire size	线缆 OD (mm) Cable OD (mm)	剥线长度 (mm) Strip length (mm)	导体铆压 (A-A) Conductor crimp			绝缘体铆压 (B-B) Insulation crimp	
					压接宽度CB1 Crimping width CB1±0.03mm	压接宽度CBm1 Crimping height CBm1+0.05mm	压接高度 Crimping height CH1±0.03mm	压接宽度CBm2 Crimping width CBm2±0.05mm	压接高度CH2 Crimping width CH2±0.08mm
WF1503-TPSN01	UL 1007	28 AWG	1.20±0.1	2.00±0.10mm	1.05	1.04	0.67	1.40	1.60
	UL 1007	26 AWG	1.30±0.1		1.05	1.05	0.74	1.45	1.60
	UL 1007	24 AWG	1.40±0.1		1.20	1.20	0.81	1.50	1.60

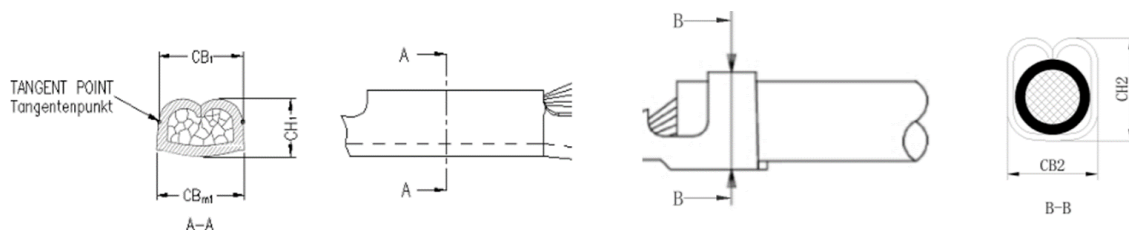

Dimensions 尺寸

Ordering Information 订购信息

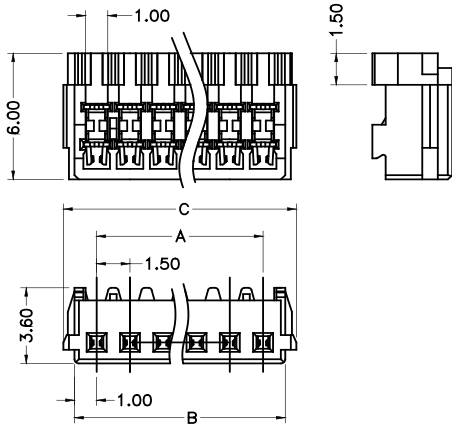

Circuit 芯数	Part number 型号	Dimensions 尺寸 (mm)			Parkage 包装 Q'ty/Bag 只/袋装	Remake 可量产状态
		A	B	C		
2	WF1503-HI02X01	1.50	3.50	4.50	1000	
3	WF1503-HI03X01	3.00	5.00	6.00	1000	
4	WF1503-HI04X01	4.50	6.50	7.50	1000	
5	WF1503-HI05X01	6.00	8.00	9.00	1000	
6	WF1503-HI06X01	7.50	9.50	10.50	1000	
7	WF1503-HI07X01	9.00	11.00	12.00	1000	
8	WF1503-HI08X01	10.50	12.50	13.50	1000	*
9	WF1503-HI09X01	12.00	14.00	15.00	1000	
10	WF1503-HI10X01	13.50	15.50	16.50	1000	
11	WF1503-HI11X01	15.00	17.00	18.00	1000	
12	WF1503-HI12X01	16.50	18.50	19.50	1000	
13	WF1503-HI13X01	18.00	20.0	21.00	1000	
14	WF1503-HI14X01	19.50	21.50	22.50	1000	
15	WF1503-HI15X01	21.00	23.00	24.00	1000	
16	WF1503-HI16X01	22.50	24.50	25.50	1000	
17	WF1503-HI17X01	24.00	26.00	27.00	1000	
18	WF1503-HI18X01	25.50	27.50	28.50	1000	
19	WF1503-HI19X01	27.00	29.00	30.00	1000	
20	WF1503-HI20X01	28.50	30.50	31.50	1000	

Note: * stands for mass production . 注: *代表可量产

WF1503 Series

Model number allocation 型号命名

WF1503	-	XX	XX	E	X	1
(1)		(2)	(3)	(4)	(5)	(6)
(1) Series (系列): Wafer 1.50mm Series				(4) Color(颜色): E=Natural		
(2) Terminal type (端子形态): WS=S/T DIP WR=R/A DIP WM=S/T SMT WZ=R/A SMT				(5) Packing (包装): 0=PE Bag、T=Tuble、R=Reel		
(3) Circuit (位数): 02=2.....20=20P				(6) Internal code (流水码):		

WF1503	-	XX	XX	XX	X	1
(1)		(2)	(3)	(4)	(5)	(6)
(1) Series (系列): Wafer 1.50mm Series				(4) Color(颜色): B=Black、W=White、E=Beige		
(2) Product type (产品类型): H=Crimp Type Housing HI= IDC Type Housing				(5) Packing (包装): 0=PE Bag、T=Tuble		
(3) Circuit (位数): 02=2.....20=20P				(6) Internal code (流水码)		

Contact Us 联系我们

维峰电子股份有限公司(总部)
WCON ELECTRONICS CO.,LTD(HQ)
地址:广东省东莞市虎门镇大宁文明路15号
Add :No.15,Wenming Road,Daning Community, Humen Town,
Dongguan, Guangdong.523930, China

昆山维康电子有限公司
KUNSHAN WCON ELECTRONICIS CO.,LTD(East of China)
地址:昆山市千灯镇汶浦中路169号
Add : No.169, WenPu Middle Road, QianDeng Town, Kunshan
City, Jiangsu Province, China

合肥维峰电子有限公司
HEFEI WCON ELECTRONICIS CO.,LTD
地址:安徽合肥市高新技术开发区绿城科技园E栋2楼
Add : 2F, Building E, Greentown Science Park,High-tech Develop-
ment Zone, Hefei, Anhui,China

维康电子(泰国)有限公司
WCON ELECTRONICS (Thailand) CO.,LTD
地址:泰国巴真武里府西玛铺县华瓦区洛加纳工业园
Add: VG3C+H57, Hua Wa, Si Maha Phot District, Prachin Buri
25140, Thailand

销售联系方式 Sales Contacts

国际客户部 International Sales Department
salesdg01@wcon.com
salesdg05@wcon.com

大客户专线 Key Account Line
华南: salesdg28@wcon.com
华东: salesks@wcon.com

中小客户专线 Small and Medium-sized Account Line
华南: salesdg10@wcon.com
华东: salesks01@wcon.com

网络销售 Online sales
salesdg26@wcon.com



Official Website



Product e-catalog



WeChat Public#



TikTok Public#