

# HSF

**NOTES:**

Rated Current: 3.0AMP.(20°C,1\*2P-1\*15P)  
 2.0AMP.(20°C,1\*16P-1\*40P)  $\triangle A4$   
 Contact Resistance: 20m $\Omega$  Max.  
 Withstand Voltage: 500V AC/DC  
 Insulation Resistance: 1000M $\Omega$  Min.  
 Operation Temperature: -40°C to +125°C(Gold Plating)  $\triangle A4$   
 -40°C to +105°C(Tin Plating)  $\triangle A4$

Contact Material: Copper Alloy  
 Contact Plating: Au or Sn Over 30u" Min Ni  $\triangle A4$   
 Insulator Material: PA9T+G.F UL94V-0 BK  $\triangle A4$

## Ordering Information

1220- 2 1 XX XX M XXX C R XX  $\triangle A1$

Plastic Layer

Plastic Row

No. of Pins  
Per Row: 02-40

Contact Plating  
 G0=Gold Flash  
 G3=10u"Au, BG3=8u"PdNi+2u"Au  
 G4=15u"Au, BG4=13u"PdNi+2u"Au  
 G5=30u"Au, BG5=28u"PdNi+2u"Au  
 S0=Gold Flash/Tin  
 S3=10u"Au/Sn, P3=8u"PdNi+2u"Au/Sn  
 S4=15u"Au/Sn, P4=13u"PdNi+2u"Au/Sn  
 S5=30u"Au/Sn, P5=28u"PdNi+2u"Au/Sn  $\triangle A4$   
 SN=Bright Tin  
 SM=Matte Tin

Series No.  
01-99

Packing  
 T=Tube  
 P=Tube+CAP  
 R=Tape&Reel+CAP

Insulator Material  
C=PA9T

Pin Length  
L(See Table)

Type:  
M:SMT

PIN(PerRow)	2-15P	16-25P	26-40P
M	0.10	0.15	0.18 $\triangle A3$

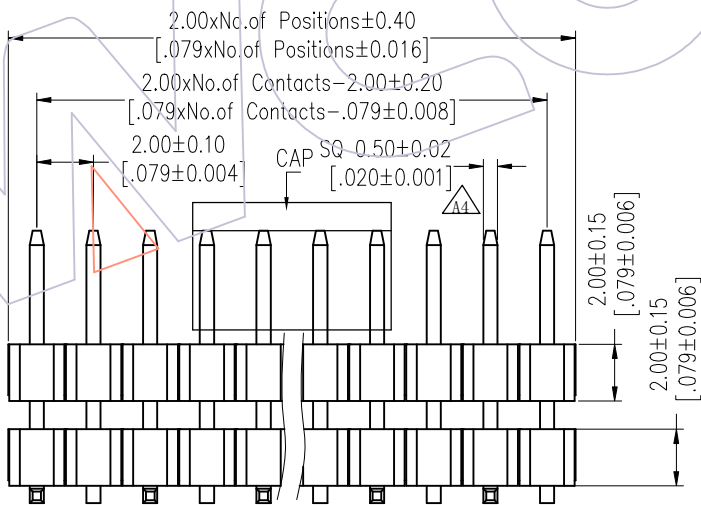
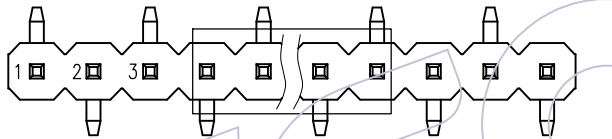
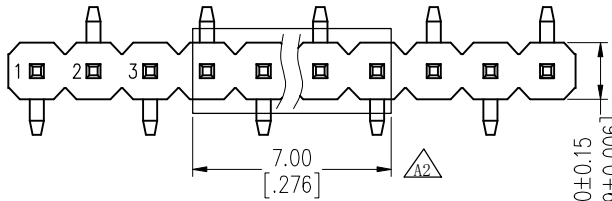

Recommended P.C.B Layout (Top Side)  
 (PCB BOARD TOLERANCE±0.05)  
 (PCB Thickness: T=1.60m)

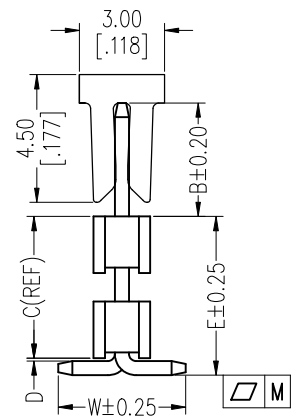
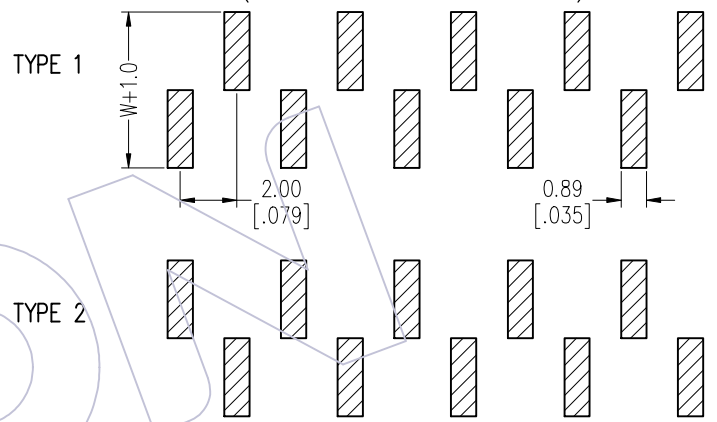

REV	DATE	MODIFICATION DESCRIPTION	CHANGE	DIM	TOL	APPROVE	DATE	PROJ.	SCALE	Fit	PART NO.	TITLE:
A4	2025/08/07	Standardization Drawing	CP	OPERATION	DRAW	DATE	2025/08/07	UNIT	mm	Fit	1220-21XXXXMXXXCRXX $\triangle A1$	PH2.00 SINGLE ROW DOUBLE PLASTIC SMT H=2.0
A3	2023/02/02	Add Flatness	Du Ying	x.X ±0.40	CP	DATE	2025/08/07	SIZE	A4			
A2	2019/07/20	Modify CAP	Liu	x.XX ±0.25	CHECK	DATE	2025/08/07	SHEET	1/6			
A0	2012/04/26	NEW	William Chen	x.XXX ±0.15	TANG	DATE	2025/08/07	PROJ.				
				Angle ± 3°	APPROVE	DATE	2025/08/07				Customer NO.	
					Steven Zhao							

**WCON**  
 Http: www.wcon.com

WCON-Dongguan  
 Tel: +86 769 85358920  
 Fax: +86 769 85358915  
 E-mail: sales@wcon.com

WCON-Kunshan  
 Tel: +86 512 57468408  
 Fax: +86 512 57468468  
 E-mail: salesks@wcon.com

**HSF**

**Packing:**

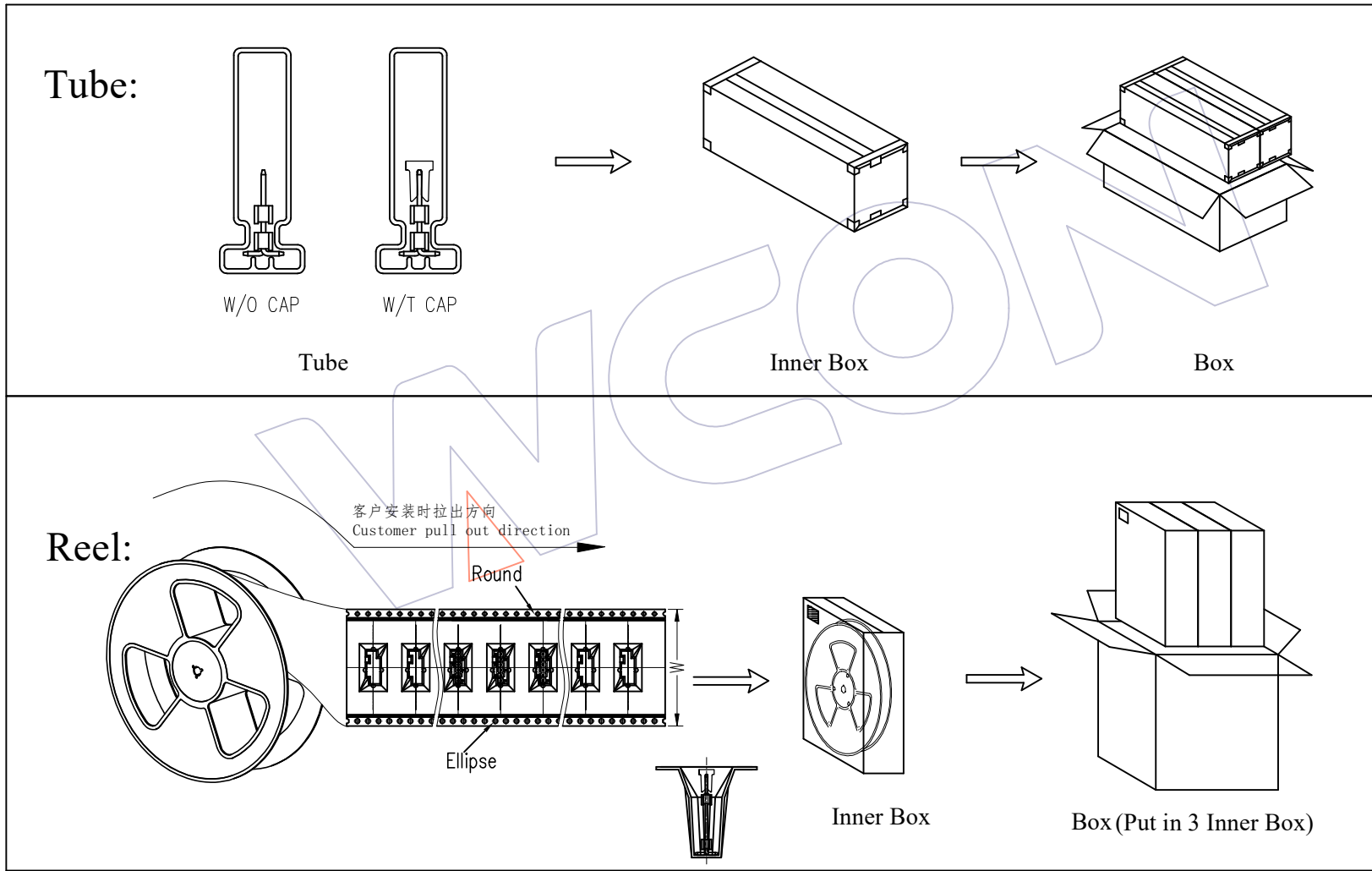

A4	2025/08/07	Standardization Drawing	CP	OPERATION	DRAW	DATE	SCALE	Fit	PART NO.
A3	2023/02/02	Add Flatness	Du Ying	x.X ±0.40	CP	2025/08/07	UNIT	mm	1220-21XXXXMXXXXCRXX
A2	2019/07/20	Modify CAP	Liu	x.XX ±0.25	CHECK	DATE	SIZE	A4	TITLE:
A0	2012/04/26	NEW	William Chen	x.XXX ±0.15	TANG	2025/08/07	SHEET	2/6	PH2.00 SINGLE ROW DOUBLE PLASTIC SMT H=2.0
REV	DATE	MODIFICATION DESCRIPTION	CHANGE	Angle ± 3°	APPROVE	DATE	PROJ.		Customer NO.
				DIM TOL	Steven Zhao	2025/08/07			

**WCON**  
Http: www.wcon.com

WCON-Dongguan      WCON-Kunshan  
Tel: +86 769 85358920      Tel: +86 512 57468408  
Fax: +86 769 85358915      Fax: +86 512 57468468  
E-mail: sales@wcon.com      E-mail: salesks@wcon.com

**HSF**



**Table**

**Packaging Quantity Refers To The Following Table**

Item	L	E	C	D	W	B	Mating
Standard	11.8	7.4	6.8	0.10	4.5	2.5	2220T/2221/2228
	12.3					3.0	2227T/2228T/2245
	12.8					3.5	2235/2240N/2243C
	13.3					4.0	2240/2243/2245T/2263/2272
	12.8	8.6	8.0			2.5	2220T/2221/2228
	13.3					3.0	2227T/2228T/2245
	13.8					3.5	2235/2240N/2243C
	14.2					4.0	2240/2243/2245T/2263/2272
	13.6	9.4	8.8			2.5	2220T/2221/2228
	14.0					3.0	2227T/2228T/2245
	14.5					3.5	2235/2240N/2243C
	15.0					4.0	2240/2243/2245T/2263/2272
	15.3	11.1	10.5			2.5	2220T/2221/2228
	15.8					3.0	2227T/2228T/2245
	16.3					3.5	2235/2240N/2243C
	16.8					4.0	2240/2243/2245T/2263/2272
	16.5	12.4	11.8			2.5	2220T/2221/2228
	17.0					3.0	2227T/2228T/2245
	17.5					3.5	2235/2240N/2243C
	18.0					4.0	2240/2243/2245T/2263/2272
18.5	14.2	13.6	2.5	2220T/2221/2228			
18.8			3.0	2227T/2228T/2245			
19.5			3.5	2235/2240N/2243C			
19.8			4.0	2240/2243/2245T/2263/2272			
Alternate							

PINS	Q'ty/Tube	Q'ty/Inner Box	Q'ty/Box
4	69	5,520	11,040
5	55	4,400	8,800
6	48	3,840	7,680
7	40	3,200	6,400
8	35	2,800	5,600
9	31	2,480	4,960
10	28	2,240	4,480
11	25	2,000	4,000
12	23	1,840	3,680
13	21	1,680	3,360
14	20	1,600	3,200
15	19	1,520	3,040
16	17	1,360	2,720
17	16	1,280	2,560
18	15	1,200	2,400
19	15	1,200	2,400
20	14	1,120	2,240
21	13	1,040	2,080
22	13	1,040	2,080

PINS	Q'ty/Tube	Q'ty/Inner Box	Q'ty/Box
23	12	960	1,920
24	11	880	1,760
25	11	880	1,760
26	11	880	1,760
27	10	800	1,600
28	10	800	1,600
29	9	720	1,440
30	9	720	1,440
31	9	720	1,440
32	9	720	1,440
33	8	640	1,280
34	8	640	1,280
35	8	640	1,280
36	8	640	1,280
37	7	560	1,120
38	7	560	1,120
39	7	560	1,120
40	7	560	1,120

A4	2025/08/07	Standardization Drawing	CP	OPERATION	DRAW	DATE	SCALE	Fit	PART NO.	 Http: www.wcon.com WCON-Dongguan Tel: +86 769 85358920 WCON-Kunshan Tel: +86 512 57468408 Fax: +86 769 85358915 Fax: +86 512 57468468 E-mail: sales@wcon.com E-mail: salesks@wcon.com
A3	2023/02/02	Add Flatness	Du Ying	x.X ±0.40	CP	2025/08/07	UNIT	mm	1220-21XXXXMXXCRXX 	
A2	2019/07/20	Modify CAP	Liu	x.XX ±0.25	CHECK	DATE	SIZE	A4	TITLE:	
A0	2012/04/26	NEW	William Chen	x.XXX ±0.15	TANG	2025/08/07	SHEET	3/6	PH2.00 SINGLE ROW DOUBLE PLASTIC SMT H=2.0	
REV	DATE	MODIFICATION DESCRIPTION	CHANGE	Angle ± 3°	APPROVE	DATE	PROJ.		Customer NO.	
				DIM TOL	Steven Zhao	2025/08/07				

**HSF**

## Packaging Quantity Refers To The Following Table

E=7.4,B=2.5

E=7.4,B=3.0/3.5/4.0

E=8.0,B=2.5/3.0



E=8.0,B=3.5/4.0

PINS	W	Q'ty/Reel	Q'ty/Inner Box	Q'ty/Box
2	24	330	990	2,970
3	24	330	990	2,970
4	24	330	990	2,970
5	24	330	990	2,970
6	32	330	660	1,980
7	32	330	660	1,980
8	44	330	660	1,980
9	44	330	660	1,980
10	44	330	660	1,980
11	44	330	660	1,980
12	44	330	660	1,980
13	44	330	660	1,980
14	56	330	330	990
15	56	330	330	990
16	56	330	330	990
17	56	330	330	990
18	56	330	330	990
19	56	330	330	990
20	72	330	330	990
21	72	330	330	990
22	72	330	330	990
23	72	330	330	990
24	72	330	330	990
25	72	330	330	990
26	72	330	330	990
27	72	330	330	990
28	88	330	330	990
29	88	330	330	990
30	88	330	330	990

PINS	W	Q'ty/Reel	Q'ty/Inner Box	Q'ty/Box
2	24	290	870	2,610
3	24	290	870	2,610
4	24	290	870	2,610
5	24	290	870	2,610
6	32	290	580	1,740
7	44	290	580	1,740
8	44	290	580	1,740
9	44	290	580	1,740
10	44	290	580	1,740
11	44	290	580	1,740
12	44	290	580	1,740
13	56	290	290	870
14	56	290	290	870
15	56	290	290	870
16	56	290	290	870
17	56	290	290	870
18	56	290	290	870
19	72	290	290	870
20	72	290	290	870
21	72	290	290	870
22	72	290	290	870
23	72	290	290	870
24	72	290	290	870
25	72	290	290	870
26	72	290	290	870
27	88	290	290	870
28	88	290	290	870
29	88	290	290	870
30	88	290	290	870

PINS	W	Q'ty/Reel	Q'ty/Inner Box	Q'ty/Box
2	24	290	870	2,610
3	24	290	870	2,610
4	24	290	870	2,610
5	24	290	870	2,610
6	32	290	580	1,740
7	44	290	580	1,740
8	44	290	580	1,740
9	44	290	580	1,740
10	44	290	580	1,740
11	44	290	580	1,740
12	44	290	580	1,740
13	56	290	290	870
14	56	290	290	870
15	56	290	290	870
16	56	290	290	870
17	56	290	290	870
18	56	290	290	870
19	72	290	290	870
20	72	290	290	870
21	72	290	290	870
22	72	290	290	870
23	72	290	290	870
24	72	290	290	870
25	72	290	290	870
26	72	290	290	870
27	88	290	290	870
28	88	290	290	870
29	88	290	290	870
30	88	290	290	870

PINS	W	Q'ty/Reel	Q'ty/Inner Box	Q'ty/Box
2	24	250	750	2,250
3	24	250	750	2,250
4	24	250	750	2,250
5	32	250	500	1,500
6	32	250	500	1,500
7	44	250	500	1,500
8	44	250	500	1,500
9	44	250	500	1,500
10	44	250	500	1,500
11	44	250	500	1,500
12	44	250	500	1,500
13	56	250	250	750
14	56	250	250	750
15	56	250	250	750
16	56	250	250	750
17	56	250	250	750
18	56	250	250	750
19	72	250	250	750
20	72	250	250	750
21	72	250	250	750
22	72	250	250	750
23	72	250	250	750
24	72	250	250	750
25	72	250	250	750
26	72	250	250	750
27	88	250	250	750
28	88	250	250	750
29	88	250	250	750
30	88	250	250	750

REV	DATE	MODIFICATION DESCRIPTION	CHANGE	DIM	TOL	APPROVE	DATE	PROJ.	SCALE	Fit	PART NO.	TITLE:	Customer NO.
A4	2025/08/07	Standardization Drawing	CP			DRAW	2025/08/07		UNIT	mm	1220-21XXXXMXXXCRXX 		
A3	2023/02/02	Add Flatness	Du Ying	x.X	±0.40	CP	2025/08/07		SIZE	A4			
A2	2019/07/20	Modify CAP	Liu	x.XX	±0.25	CHECK	2025/08/07		SHEET	4/6			
A0	2012/04/26	NEW	William Chen	x.XXX	±0.15	TANG	2025/08/07		PROJ.				
				Angle	± 3°	APPROVE	2025/08/07						
						Steven Zhao							



Http: [www.wcon.com](http://www.wcon.com)

WCON-Dongguan Tel: +86 769 85358920 Fax: +86 769 85358915 E-mail: <a href="mailto:sales@wcon.com">sales@wcon.com</a>	WCON-Kunshan Tel: +86 512 57468408 Fax: +86 512 57468468 E-mail: <a href="mailto:salesks@wcon.com">salesks@wcon.com</a>
---	--



## Packaging Quantity Refers To The Following Table

E=8.8,B=2.5/3.0

E=8.8,B=3.5/4.0

E=11.1,B=2.5

E=11.1,B=3.0/3.5/4.0

PINS	W	Q'ty/Reel	Q'ty/Inner Box	Q'ty/Box
2	24	250	750	2,250
3	24	250	750	2,250
4	24	250	750	2,250
5	32	250	500	1,500
6	32	250	500	1,500
7	44	250	500	1,500
8	44	250	500	1,500
9	44	250	500	1,500
10	44	250	500	1,500
11	44	250	500	1,500
12	44	250	500	1,500
13	56	250	250	750
14	56	250	250	750
15	56	250	250	750
16	56	250	250	750
17	56	250	250	750
18	56	250	250	750
19	72	250	250	750
20	72	250	250	750
21	72	250	250	750
22	72	250	250	750
23	72	250	250	750
24	72	250	250	750
25	72	250	250	750
26	72	250	250	750
27	88	250	250	750
28	88	250	250	750
29	88	250	250	750
30	88	250	250	750

PINS	W	Q'ty/Reel	Q'ty/Inner Box	Q'ty/Box
2	24	250	750	2,250
3	24	250	750	2,250
4	24	250	750	2,250
5	32	250	500	1,500
6	32	250	500	1,500
7	44	250	500	1,500
8	44	250	500	1,500
9	44	250	500	1,500
10	44	250	500	1,500
11	44	250	500	1,500
12	56	250	250	750
13	56	250	250	750
14	56	250	250	750
15	56	250	250	750
16	56	250	250	750
17	56	250	250	750
18	72	250	250	750
19	72	250	250	750
20	72	250	250	750
21	72	250	250	750
22	72	250	250	750
23	72	250	250	750
24	72	250	250	750
25	72	250	250	750
26	88	250	250	750
27	88	250	250	750
28	88	250	250	750
29	88	250	250	750
30	88	250	250	750

PINS	W	Q'ty/Reel	Q'ty/Inner Box	Q'ty/Box
2	24	250	750	2,250
3	24	250	750	2,250
4	24	250	750	2,250
5	32	250	500	1,500
6	32	250	500	1,500
7	44	250	500	1,500
8	44	210	420	1,260
9	44	210	420	1,260
10	44	210	420	1,260
11	44	250	250	1,500
12	56	250	250	750
13	56	250	250	750
14	56	250	250	750
15	56	250	250	750
16	56	250	250	750
17	56	250	250	750
18	72	250	250	750
19	72	250	250	750
20	72	250	250	750
21	72	250	250	750
22	72	250	250	750
23	72	250	250	750
24	72	250	250	750
25	72	250	250	750
26	88	250	250	750
27	88	250	250	750
28	88	250	250	750
29	88	250	250	750
30	88	250	250	750

PINS	W	Q'ty/Reel	Q'ty/Inner Box	Q'ty/Box
2	24	210	630	1,890
3	24	210	630	1,890
4	24	210	630	1,890
5	32	210	420	1,260
6	32	210	420	1,260
7	44	210	420	1,260
8	44	210	420	1,260
9	44	210	420	1,260
10	44	210	420	1,260
11	44	210	420	1,260
12	56	210	210	630
13	56	210	210	630
14	56	210	210	630
15	56	210	210	630
16	56	210	210	630
17	56	210	210	630
18	72	210	210	630
19	72	210	210	630
20	72	210	210	630
21	72	210	210	630
22	72	210	210	630
23	72	210	210	630
24	72	210	210	630
25	72	210	210	630
26	88	210	210	630
27	88	210	210	630
28	88	210	210	630
29	88	210	210	630
30	88	210	210	630

A4	2025/08/07	Standardization Drawing	CP	OPERATION	DRAW	DATE	SCALE	Fit	PART NO.
A3	2023/02/02	Add Flatness	Du Ying	x.xx ±0.40	CP	2025/08/07	UNIT	mm	1220-21XXXXMXXCRXX
A2	2019/07/20	Modify CAP	Liu	x.xxx ±0.25	CHECK	DATE	SIZE	A4	TITLE:
A0	2012/04/26	NEW	William Chen	x.xxx ±0.15	TANG	2025/08/07	SHEET	5/6	PH2.00 SINGLE ROW DOUBLE PLASTIC SMT H=2.0
REV	DATE	MODIFICATION DESCRIPTION	CHANGE	Angle ± 3° DIM TOL	APPROVE Steven Zhao	DATE	PROJ.		Customer NO.



WCON-Dongguan Tel: +86 769 85358920 Fax: +86 769 85358915 E-mail: sales@wcon.com	WCON-Kunshan Tel: +86 512 57468408 Fax: +86 512 57468468 E-mail: sales@wcon.com
---	--



## Packaging Quantity Refers To The Following Table

E=12.4,B=2.5/3.0

E=12.4,B=3.5/4.0

E=14.2 B=2.5/3.0

E=14.2 B=3.5/4.0

PINS	W	Q'ty/Reel	Q'ty/Inner Box	Q'ty/Box
2	24	210	630	1,890
3	24	210	630	1,890
4	32	210	420	1,260
5	32	210	420	1,260
6	32	210	420	1,260
7	44	210	420	1,260
8	44	210	420	1,260
9	44	210	420	1,260
10	44	210	420	1,260
11	44	210	420	1,260
12	56	210	210	630
13	56	210	210	630
14	56	210	210	630
15	56	210	210	630
16	56	210	210	630
17	56	210	210	630
18	72	210	210	630
19	72	210	210	630
20	72	210	210	630
21	72	210	210	630
22	72	210	210	630
23	72	210	210	630
24	72	210	210	630
25	72	210	210	630
26	88	210	210	630
27	88	210	210	630
28	88	210	210	630
29	88	210	210	630
30	88	210	210	630

PINS	W	Q'ty/Reel	Q'ty/Inner Box	Q'ty/Box
2	24	210	630	1,890
3	24	210	630	1,890
4	32	210	420	1,260
5	32	210	420	1,260
6	44	210	420	1,260
7	44	210	420	1,260
8	44	210	420	1,260
9	44	210	420	1,260
10	44	210	420	1,260
11	56	210	210	630
12	56	210	210	630
13	56	210	210	630
14	56	210	210	630
15	56	210	210	630
16	56	210	210	630
17	72	210	210	630
18	72	210	210	630
19	72	210	210	630
20	72	210	210	630
21	72	210	210	630
22	72	210	210	630
23	72	210	210	630
24	72	210	210	630
25	88	210	210	630
26	88	210	210	630
27	88	210	210	630
28	88	210	210	630
29	88	210	210	630
30	88	210	210	630

PINS	W	Q'ty/Reel	Q'ty/Inner Box	Q'ty/Box
2	24	160	480	1,440
3	24	160	480	1,440
4	32	160	320	960
5	32	160	320	960
6	44	160	320	960
7	44	160	320	960
8	44	160	320	960
9	44	160	320	960
10	44	160	320	960
11	56	160	160	480
12	56	160	160	480
13	56	160	160	480
14	56	160	160	480
15	56	160	160	480
16	56	160	160	480
17	72	160	160	480
18	72	160	160	480
19	72	160	160	480
20	72	160	160	480
21	72	160	160	480
22	72	160	160	480
23	72	160	160	480
24	72	160	160	480
25	88	160	160	480
26	88	160	160	480
27	88	160	160	480
28	88	160	160	480
29	88	160	160	480
30	88	160	160	480

PINS	W	Q'ty/Reel	Q'ty/Inner Box	Q'ty/Box
2	24	130	390	1,170
3	24	130	390	1,170
4	32	130	260	780
5	32	130	260	780
6	44	130	260	780
7	44	130	260	780
8	44	130	260	780
9	44	130	260	780
10	44	130	260	780
11	56	130	130	390
12	56	130	130	390
13	56	130	130	390
14	56	130	130	390
15	56	130	130	390
16	56	130	130	390
17	72	130	130	390
18	72	130	130	390
19	72	130	130	390
20	72	130	130	390
21	72	130	130	390
22	72	130	130	390
23	72	130	130	390
24	72	130	130	390
25	88	130	130	390
26	88	130	130	390
27	88	130	130	390
28	88	130	130	390
29	88	130	130	390
30	88	130	130	390

A4	2025/08/07	Standardization Drawing	CP	OPERATION	DRAW	DATE	SCALE	Fit	PART NO.
A3	2023/02/02	Add Flatness	Du Ying	x.X ±0.40	CP	2025/08/07	UNIT	mm	1220-21XXXXMXXXCRXX
A2	2019/07/20	Modify CAP	Liu	x.XX ±0.25	CHECK	DATE	SIZE	A4	TITLE:
A0	2012/04/26	NEW	William Chen	x.XXX ±0.15	TANG	2025/08/07	SHEET	6/6	PH2.00 SINGLE ROW DOUBLE PLASTIC SMT H=2.0
REV	DATE	MODIFICATION DESCRIPTION	CHANGE	Angle ± 3°	APPROVE	DATE	PROJ.		Customer NO.
				DIM TOL	Steven Zhao	2025/08/07			

Http: [www.wcon.com](http://www.wcon.com)

WCON-Dongguan Tel: +86 769 85358920 Fax: +86 769 85358915 E-mail: <a href="mailto:sales@wcon.com">sales@wcon.com</a>	WCON-Kunshan Tel: +86 512 57468408 Fax: +86 512 57468468 E-mail: <a href="mailto:salesks@wcon.com">salesks@wcon.com</a>
---	--