

HSF

NOTES:

Rated Current: 3.0AMP.(20°C,2*2P-2*15P)

2.0AMP.(20°C,2*16P-2*40P) $\triangle A2$

Contact Resistance: 20mΩ Max.

Withstand Voltage: 500V AC/DC

Insulation Resistance: 1000MΩ Min.

Operation Temperature: -40°C to +125°C(Gold Plating)

-40°C to +105°C(Tin Plating) $\triangle A2$

Contact Material: Copper Alloy

Contact Plating: Au or Sn Over 30u" Min Ni $\triangle A2$

Insulator Material: PA9T+G.F UL94V-0 BK $\triangle A2$

Ordering Information

1220-1 2 XX XX S XXX C X XX $\triangle A2$

Plastic Layer

Plastic Row

No. of Pins
Per Row: 02-40

Contact Plating

G0=Gold Flash
G3=10u"Au, BG3=8u"PdNi+2u"Au
G4=15u"Au, BG4=13u"PdNi+2u"Au
G5=30u"Au, BG5=28u"PdNi+2u"Au
S0=Gold Flash/Tin
S3=10u"Au/Sn, P3=8u"PdNi+2u"Au/Sn
S4=15u"Au/Sn, P4=13u"PdNi+2u"Au/Sn
S5=30u"Au/Sn, P5=28u"PdNi+2u"Au/Sn
SN=Bright Tin
SM=Matte Tin

Series No.
01-99

Packing
0=PE Bag
T=Tube
R=Tape&Reel+CAP

Insulator Material
C=PA9T

Pin Length
L(See Table)

Type:
S:S/T

Item	Pin Length	A	B	Mating
Standard	7.3	2.8	2.5	2220T/2221/2228
	7.8		3.0	2227T/2228T/2245
	8.3		3.5	2235/2240N/2243C
	8.8		4.0	2240/2243/2245T/2263/2272
Standard	6.5	2.00 (THR)	2.5	2220T/2221/2228
	7.0		3.0	2227T/2228T/2245
	7.5		3.5	2235/2240N/2243C
	8.0		4.0	2240/2243/2245T/2263/2272
Alternate				

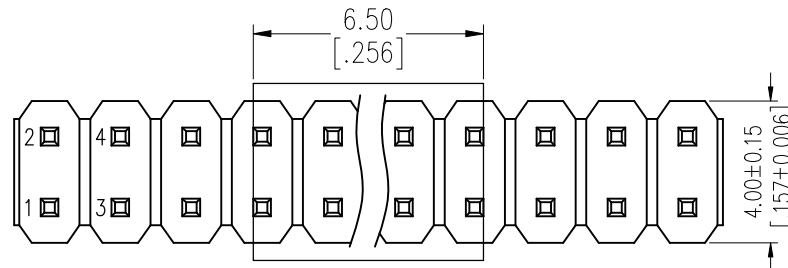

Recommended P.C.B Layout (Top Side)
(PCB BOARD TOLERANCE±0.05)
(PCB Thickness: T=1.60mm)

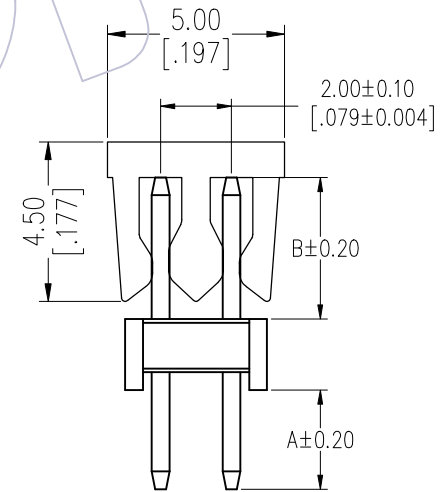
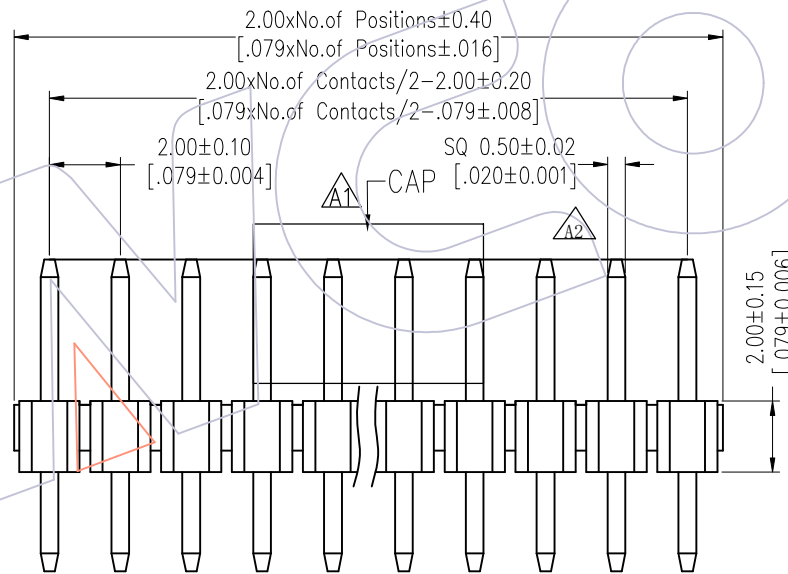
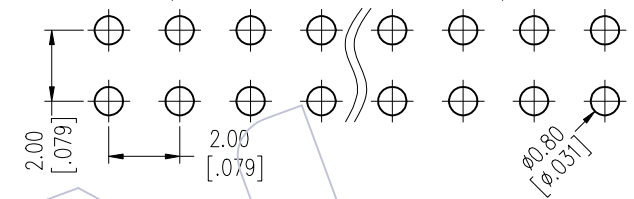

OPERATION	DRAW	DATE	SCALE	Fit	PART NO.
x.x ±0.40	CP	2025/08/05	UNIT	mm	1220-12XXXXSXXXX
x.xx ±0.25	CHECK	DATE	SIZE	A4	TITLE:
x.xxx ±0.15	TANG	2025/08/05	SHEET	1/4	PH2.00 DUAL ROW 180° H=2.0
Angle ± 3°	APPROVE	DATE	PROJ.		Customer NO.
DIM TOL	Steven Zhao	2025/08/05			

OPERATION	DRAW	DATE	SCALE	Fit	PART NO.
x.x ±0.40	CP	2025/08/05	UNIT	mm	1220-12XXXXSXXXX
x.xx ±0.25	CHECK	DATE	SIZE	A4	TITLE:
x.xxx ±0.15	TANG	2025/08/05	SHEET	1/4	PH2.00 DUAL ROW 180° H=2.0
Angle ± 3°	APPROVE	DATE	PROJ.		Customer NO.
DIM TOL	Steven Zhao	2025/08/05			

WCON
Http: www.wcon.com

WCON-Dongguan
Tel: +86 769 85358920
Fax: +86 769 85358915
E-mail: sales@wcon.com

WCON-Kunshan
Tel: +86 512 57468408
Fax: +86 512 57468468
E-mail: salesks@wcon.com

REV	DATE	MODIFICATION DESCRIPTION	CHANGE
A2	2025/08/05	Standardization Drawing	CP
A1	2024/09/05	Add CAP	DuYing
A0	2012/04/26	NEW	William Chen

HSF

Packing:

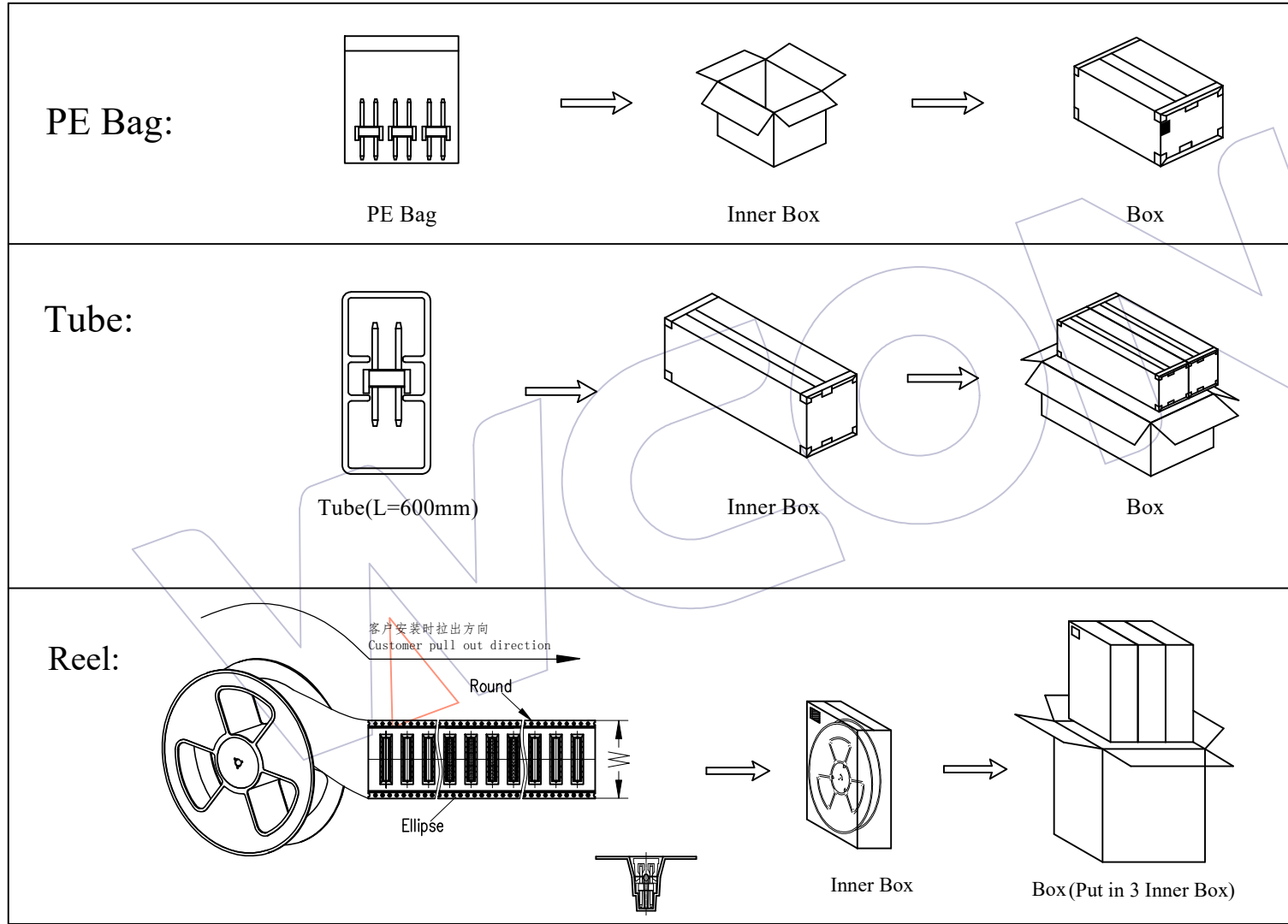

REV	DATE	MODIFICATION DESCRIPTION	CHANGE	OPERATION	DRAW	DATE	SCALE	Fit	PART NO.
A2	2025/08/05	Standardization Drawing	CP	x.X ±0.40	CP	2025/08/05	UNIT	mm	1220-12XXXXSXXXXX
A1	2024/09/05	Add CAP	DuYing	x.XX ±0.25	CHECK	DATE	SIZE	A4	TITLE:
A0	2012/04/26	NEW	William Chen	x.XXX ±0.15	TANG	2025/08/05	SHEET	2/4	PH2.00 DUAL ROW 180° H=2.0
				Angle ± 3°	APPROVE	DATE	PROJ.		Customer NO.
				DIM TOL	Steven Zhao	2025/08/05			

WCON
Http: www.wcon.com

WCON-Dongguan
Tel: +86 769 85358920
Fax: +86 769 85358915
E-mail: sales@wcon.com

WCON-Kunshan
Tel: +86 512 57468408
Fax: +86 512 57468468
E-mail: salesks@wcon.com

HSF

Packaging Quantity Refers To The Following Table

PINS /Row	Q'ty/Bag (L ≤ 10.0)	PINS /Row	Q'ty/Bag (L ≤ 10.0)
1	1000	21	200
2	1000	22	200
3	1000	23	200
4	1000	24	150
5	1000	25	150
6	500	26	150
7	500	27	150
8	500	28	150
9	500	29	150
10	500	30	100
11	300	31	100
12	300	32	100
13	300	33	100
14	300	34	100
15	300	35	100
16	300	36	100
17	200	37	100
18	200	38	100
19	200	39	100
20	200	40	100

PINS /Row	Q'ty/Tube	Q'ty/Inner Box	Q'ty/Box	PINS /Row	Q'ty/Tube	Q'ty/Inner Box	Q'ty/Box
4	69	8,280	16,560	23	12	1,440	2,880
5	55	6,600	13,200	24	11	1,320	2,640
6	48	5,760	11,520	25	11	1,320	2,640
7	40	4,800	9,600	26	11	1,320	2,640
8	35	4,200	8,400	27	10	1,200	2,400
9	32	3,840	7,680	28	10	1,200	2,400
10	29	3,480	6,960	29	9	1,080	2,160
11	25	3,000	6,000	30	9	1,080	2,160
12	23	2,760	5,520	31	9	1,080	2,160
13	21	2,520	5,040	32	9	1,080	2,160
14	20	2,400	4,800	33	8	960	1,920
15	19	2,280	4,560	34	8	960	1,920
16	17	2,040	4,080	35	8	960	1,920
17	16	1,920	3,840	36	8	960	1,920
18	15	1,800	3,600	37	7	840	1,680
19	15	1,800	3,600	38	7	840	1,680
20	14	1,680	3,360	39	7	840	1,680
21	13	1,560	3,120	40	7	840	1,680
22	13	1,560	3,120				

A2	2025/08/05	Standardization Drawing	CP	OPERATION x.x ±0.40	DRAW CP	DATE 2025/08/05	SCALE UNIT	Fit mm	PART NO. 1220-12XXXXSXXXXX
A1	2024/09/05	Add CAP	DuYing	x.xx ±0.25	CHECK TANG	DATE 2025/08/05	SIZE A4		TITLE: PH2.00 DUAL ROW 180° H=2.0
A0	2012/04/26	NEW	William Chen	x.xxx ±0.15	APPROVE Steven Zhao	DATE 2025/08/05	SHEET 3/4		Customer NO.
REV	DATE	MODIFICATION DESCRIPTION	CHANGE	Angle DIM	± 3° TOL		PROJ.		

WCON
 Http: www.wcon.com

WCON-Dongguan
 Tel: +86 769 85358920
 Fax: +86 769 85358915
 E-mail: sales@wcon.com

WCON-Kunshan
 Tel: +86 512 57468408
 Fax: +86 512 57468468
 E-mail: salesks@wcon.com

HSF

Packaging Quantity Refers To The Following Table

B=2.5/3.0/3.5

B=2.5/3.0/3.5

B=4.0

B=4.0

PINS /Row	W	Q'ty/Reel	Q'ty/Inner Box	Q'ty/Box	PINS /Row	W	Q'ty/Reel	Q'ty/Inner Box	Q'ty/Box	PINS /Row	W	Q'ty/Reel	Q'ty/Inner Box	Q'ty/Box	PINS /Row	W	Q'ty/Reel	Q'ty/Inner Box	Q'ty/Box
2	16	550	2,200	6,600	19	56	550	550	1,650	2	24	500	1,500	4,500	19	56	500	500	1,500
3	24	550	1,650	4,950	20	56	550	550	1,650	3	24	500	1,500	4,500	20	72	500	500	1,500
4	24	550	1,650	4,950	21	72	550	550	1,650	4	24	500	1,500	4,500	21	72	500	500	1,500
5	24	550	1,650	4,950	22	72	550	550	1,650	5	24	500	1,500	4,500	22	72	500	500	1,500
6	24	550	1,650	4,950	23	72	550	550	1,650	6	32	500	1,000	3,000	23	72	500	500	1,500
7	32	550	1,100	3,300	24	72	550	550	1,650	7	32	500	1,000	3,000	24	72	500	500	1,500
8	32	550	1,100	3,300	25	72	550	550	1,650	8	44	500	1,000	3,000	25	72	500	500	1,500
9	44	550	1,100	3,300	26	72	550	550	1,650	9	44	500	1,000	3,000	26	72	500	500	1,500
10	44	550	1,100	3,300	27	72	550	550	1,650	10	44	500	1,000	3,000	27	72	500	500	1,500
11	44	550	1,100	3,300	28	72	550	550	1,650	11	44	500	1,000	3,000	28	88	500	500	1,500
12	44	550	1,100	3,300	29	88	550	550	1,650	12	44	500	1,000	3,000	29	88	500	500	1,500
13	44	550	1,100	3,300	30	88	550	550	1,650	13	44	500	1,000	3,000	30	88	500	500	1,500
14	44	550	1,100	3,300	31	88	550	550	1,650	14	56	500	500	1,500	31	88	500	500	1,500
15	56	550	550	1,650	32	88	550	550	1,650	15	56	500	500	1,500	32	88	500	500	1,500
16	56	550	550	1,650	33	88	550	550	1,650	16	56	500	500	1,500	33	88	500	500	1,500
17	56	550	550	1,650	34	88	550	550	1,650	17	56	500	500	1,500	34	88	500	500	1,500
18	56	550	550	1,650	35	88	550	550	1,650	18	56	500	500	1,500	35	88	500	500	1,500

				OPERATION		DRAW		DATE	SCALE	Fit	PART NO. 1220-12XXXXSXXXX		 Http: www.wcon.com	
A2	2025/08/05	Standardization Drawing		CP	x.x	±0.40	CP	2025/08/05	UNIT	mm	TITLE: PH2.00 DUAL ROW 180° H=2.0			
A1	2024/09/05	Add CAP		DuYing	x.xx	±0.25	CHECK TANG	DATE 2025/08/05	SHEET	A4	Customer NO.		WCON-Dongguan Tel: +86 769 85358920 Fax: +86 769 85358915 E-mail: sales@wcon.com	WCON-Kunshan Tel: +86 512 57468408 Fax: +86 512 57468468 E-mail: salesks@wcon.com
A0	2012/04/26	NEW		William Chen	Angle	± 3'	APPROVE Steven Zhao	DATE 2025/08/05	PROJ.	4/4				
REV	DATE	MODIFICATION DESCRIPTION		CHANGE	DIM	TOL								