

HSF

NOTES:

Rated Current: 3.0AMP. (20°C, 2*2P-2*15P)
 2.0AMP. (20°C, 2*16P-2*40P) $\triangle A2$
 Contact Resistance: 20m Ω Max.
 Withstand Voltage: 500V AC/DC
 Insulation Resistance: 1000M Ω Min.
 Operation Temperature: -40°C to +125°C (Gold Plating)
 -40°C to +105°C (Tin Plating) $\triangle A2$

Contact Material: Copper Alloy
 Contact Plating: Au or Sn Over 30u" Min Ni $\triangle A2$
 Insulator Material: PA9T+G.F UL94V-0 BK $\triangle A2$

Ordering Information

1220-1 2 XX XX K XXX C X XX $\triangle A2$

Plastic Layer
 Plastic Row
 No. of Pins Per Row: 02-40
 Contact Plating
 G0=Gold Flash
 G3=10u"Au, BG3=8u"PdNi+2u"Au
 G4=15u"Au, BG4=13u"PdNi+2u"Au
 G5=30u"Au, BG5=28u"PdNi+2u"Au
 S0=Gold Flash/Tin
 S3=10u"Au/Sn, P3=8u"PdNi+2u"Au/Sn
 S4=15u"Au/Sn, P4=13u"PdNi+2u"Au/Sn
 S5=30u"Au/Sn, P5=28u"PdNi+2u"Au/Sn $\triangle A2$
 SN=Bright Tin
 SM=Matte Tin

Series No. 01-99
 Packing 0=PE Bag T=Tube
 Insulator Material C=PA9T
 Pin Length L(See Table)
 Type: K:Kink Type

Item	Pin Length	A	B	Mating
Standard	7.3	2.8	2.5	2220T/2221/2228
	7.8		3.0	2227T/2228T/2245
	8.3		3.5	2235/2240N/2243C
	8.8		4.0	2240/2243/2245T/2263/2272
Standard	6.5	2.0 (THR)	2.5	2220T/2221/2228
	7.0		3.0	2227T/2228T/2245
	7.5		3.5	2235/2240N/2243C
	8.0		4.0	2240/2243/2245T/2263/2272
Alternate				

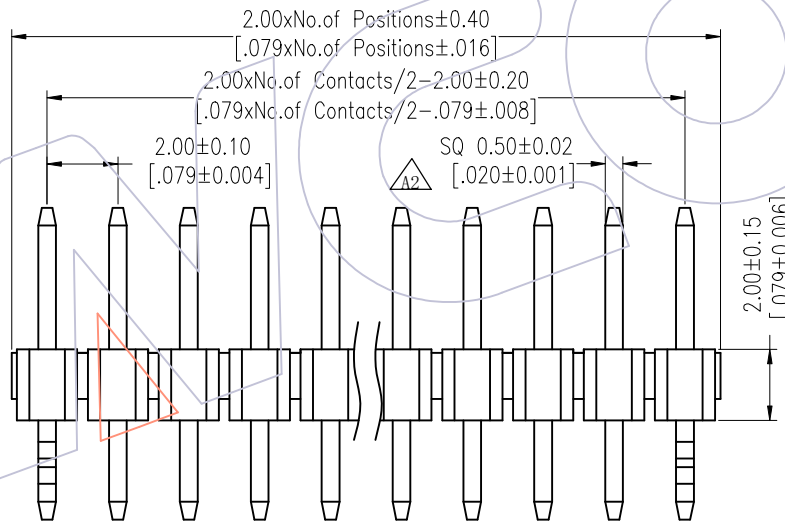
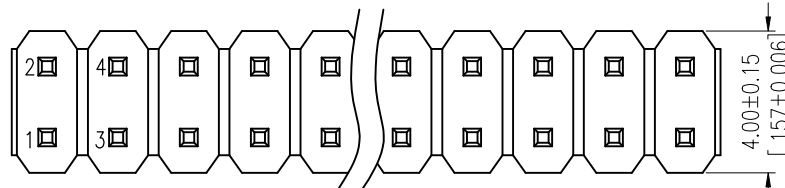

Recommended P.C.B Layout (Top Side)
 (PCB BOARD TOLERANCE±0.05)
 (PCB Thickness: T=1.60m)

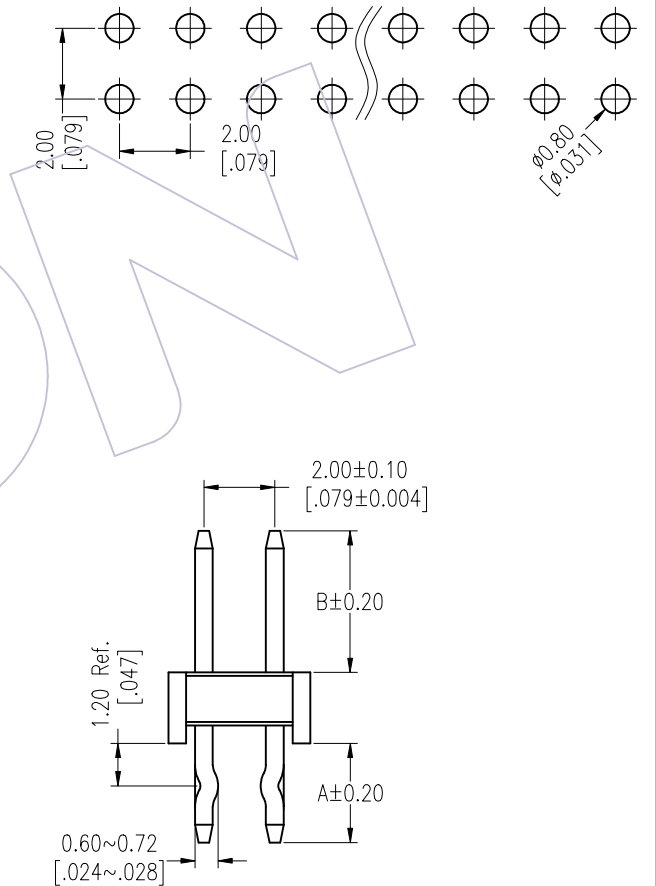

REV	DATE	MODIFICATION DESCRIPTION	CHANGE	OPERATION	DRAW	DATE	SCALE	Fit	PART NO.
A2	2025/08/06	Standardization Drawing	CP	x.X ±0.40	CP	2025/08/06	UNIT	mm	1220-12XXXXXXC0XX $\triangle A2$
A1	2018/01/18	Modify P/N	Liu	x.XX ±0.25	CHECK	DATE	SIZE	A4	TITLE: PH2.00 DUAL ROW 180° H=2.0 KINKED-PIN
AO	2012/04/26	NEW	William Chen	x.XXX ±0.15	TANG	2025/08/06	SHEET	1/3	Customer NO.
				Angle ± 3'	APPROVE	DATE	PROJ.		
				DIM TOL	Steven Zhao	2025/08/06			



Http: www.wcon.com

WCON-Dongguan Tel: +86 769 85358920 Fax: +86 769 85358915 E-mail: sales@wcon.com	WCON-Kunshan Tel: +86 512 57468408 Fax: +86 512 57468468 E-mail: salesks@wcon.com
---	--

HSF

Packing:

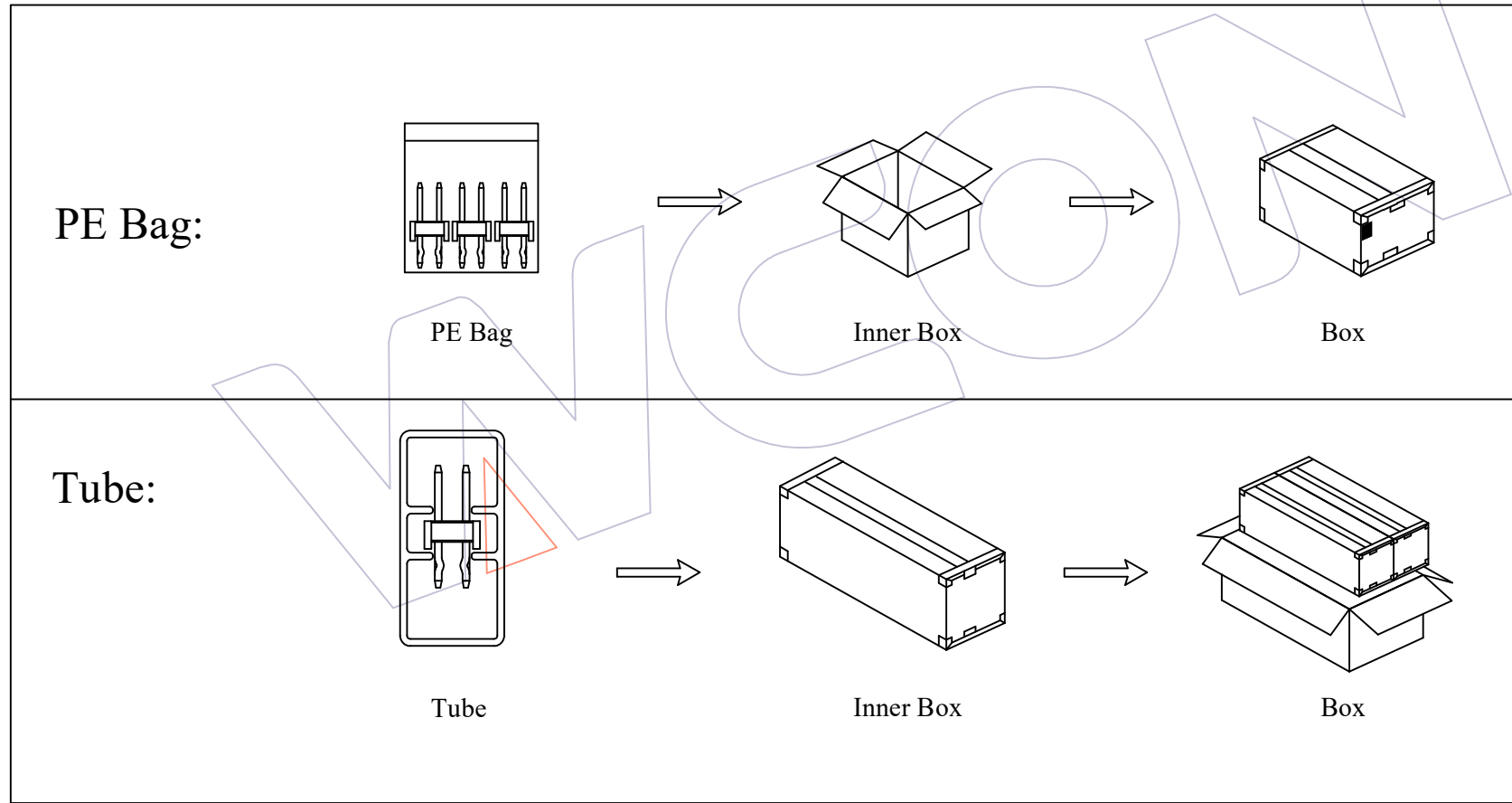



REV	DATE	MODIFICATION DESCRIPTION	CHANGE	DIM	TOL	OPERATION	DRAW	DATE	SCALE	Fit	PART NO.
A2	2025/08/06	Standardization Drawing	CP	x.x	±0.40	CP	CP	2025/08/06	UNIT	mm	1220-12XXXXXXC0XX
A1	2018/01/18	Modify P/N	Liu	x.xx	±0.25	CHECK	TANG	2025/08/06	SIZE	A4	TITLE: PH2.00 DUAL ROW 180° H=2.0 KINKED-PIN
A0	2012/04/26	NEW	William Chen	x.xxx	±0.15	APPROVE	Steven Zhao	2025/08/06	SHEET	2/3	Customer NO.

WCON
[Http: www.wcon.com](http://www.wcon.com)
 WCON-Dongguan Tel: +86 769 85358920
 WCON-Kunshan Tel: +86 512 57468408
 Fax: +86 769 85358915
 Fax: +86 512 57468468
 E-mail: sales@wcon.com
 E-mail: salesks@wcon.com

HSF

Packaging Quantity Refers To The Following Table

PINS /Row	Q'ty/Bag (L≤10.0)	PINS /Row	Q'ty/Bag (L≤10.0)	PINS /Row	Q'ty/Tube	Q'ty/Inner Box	Q'ty/Box	PINS /Row	Q'ty/Tube	Q'ty/Inner Box	Q'ty/Box
1	1000	21	200	4	69	8,280	16,560	23	12	1,440	2,880
2	1000	22	200	5	55	6,600	13,200	24	11	1,320	2,640
3	1000	23	200	6	46	5,520	11,040	25	11	1,320	2,640
4	1000	24	150	7	40	4,800	9,600	26	11	1,320	2,640
5	1000	25	150	8	35	4,200	8,400	27	10	1,200	2,400
6	500	26	150	9	31	3,720	7,440	28	10	1,200	2,400
7	500	27	150	10	28	3,360	6,720	29	9	1,080	2,160
8	500	28	150	11	25	3,000	6,000	30	9	1,080	2,160
9	500	29	150	12	23	2,760	5,520	31	9	1,080	2,160
10	500	30	100	13	21	2,520	5,040	32	9	1,080	2,160
11	300	31	100	14	20	2,400	4,800	33	8	960	1,920
12	300	32	100	15	19	2,280	4,560	34	8	960	1,920
13	300	33	100	16	17	2,040	4,080	35	8	960	1,920
14	300	34	100	17	16	1,920	3,840	36	8	960	1,920
15	300	35	100	18	15	1,800	3,600	37	7	840	1,680
16	300	36	100	19	15	1,800	3,600	38	7	840	1,680
17	200	37	100	20	14	1,680	3,360	39	7	840	1,680
18	200	38	100	21	13	1,560	3,120	40	7	840	1,680
19	200	39	100	22	13	1,560	3,120				
20	200	40	100								

A2	2025/08/06	Standardization Drawing	CP	OPERATION	DRAW	DATE	SCALE	Fit	PART NO.	 Http: www.wcon.com WCON-Dongguan Tel: +86 769 85358920 WCON-Kunshan Tel: +86 512 57468408 Fax: +86 769 85358915 Fax: +86 512 57468468 E-mail: sales@wcon.com E-mail: salesks@wcon.com
A1	2018/01/18	Modify P/N	Liu	x.X ±0.40	CP	2025/08/06	UNIT	mm	1220-12XXXXXXCOXX 	
AO	2012/04/26	NEW	William Chen	x.XX ±0.25	CHECK	DATE	SIZE	A4	TITLE:	
REV	DATE	MODIFICATION DESCRIPTION	CHANGE	x.XXX ±0.15	TANG	2025/08/06	SHEET	3/3	PH2.00 DUAL ROW 180° H=2.0 KINKED-PIN	
				Angle ± 3'	APPROVE	DATE	PROJ.		Customer NO.	
				DIM TOL	Steven Zhao	2025/08/06				