

HSF

NOTES:

Rated Current: 3.0AMP.(20°C, 1*2P-1*15P)
 2.0AMP.(20°C, 1*16P-1*40P) $\Delta 2$
 Contact Resistance: 20m Ω Max.
 Withstand Voltage: 500V AC/DC
 Insulation Resistance: 1000M Ω Min.
 Operation Temperature: -40°C to +125°C (Gold Plating) $\Delta 2$
 -40°C to +105°C (Tin Plating) $\Delta 2$
 Contact Material: Copper Alloy
 Contact Plating: Au or Sn Over 30u" Min Ni $\Delta 2$
 Insulator Material: PA9T+G.F UL94V-0 BK $\Delta 2$

Ordering Information

1220- 1 1 XX XX Z XXX C R XX $\Delta 1$

Plastic Layer
 Plastic Row
 No. of Pins
 Per Row: 02-40
 Contact Plating
 G0=Gold Flash
 G3=10u"Au, BG3=8u"PdNi+2u"Au
 G4=15u"Au, BG4=13u"PdNi+2u"Au
 G5=30u"Au, BG5=28u"PdNi+2u"Au
 S0=Gold Flash/Tin
 S3=10u"Au/Sn, P3=8u"PdNi+2u"Au/Sn
 S4=15u"Au/Sn, P4=13u"PdNi+2u"Au/Sn
 S5=30u"Au/Sn, P5=28u"PdNi+2u"Au/Sn
 SN=Bright Tin
 SM=Matte Tin
 Series No.
 01-99
 Packing
 T=Tube
 P=Tube+CAP
 R=Tape&Reel+CAP
 Insulator Material
 C=PA9T
 Pin Length
 L(See Table)
 Type:
 Z:R/A SMT

Item	Pin Length	A	B	Mating
Standard	7.5	2.8	2.5	2220T/2221/2228
	7.8		3.0	2227T/2228T/2245
	8.5		3.5	2235/2240N/2243C
	9.0		4.0	2240/2243/2245T/2263/2272
Alternate				

Recommended P.C.B Layout (Top Side)
 (PCB BOARD TOLERANCE ± 0.05)
 (PCB Thickness: T=1.60mm)

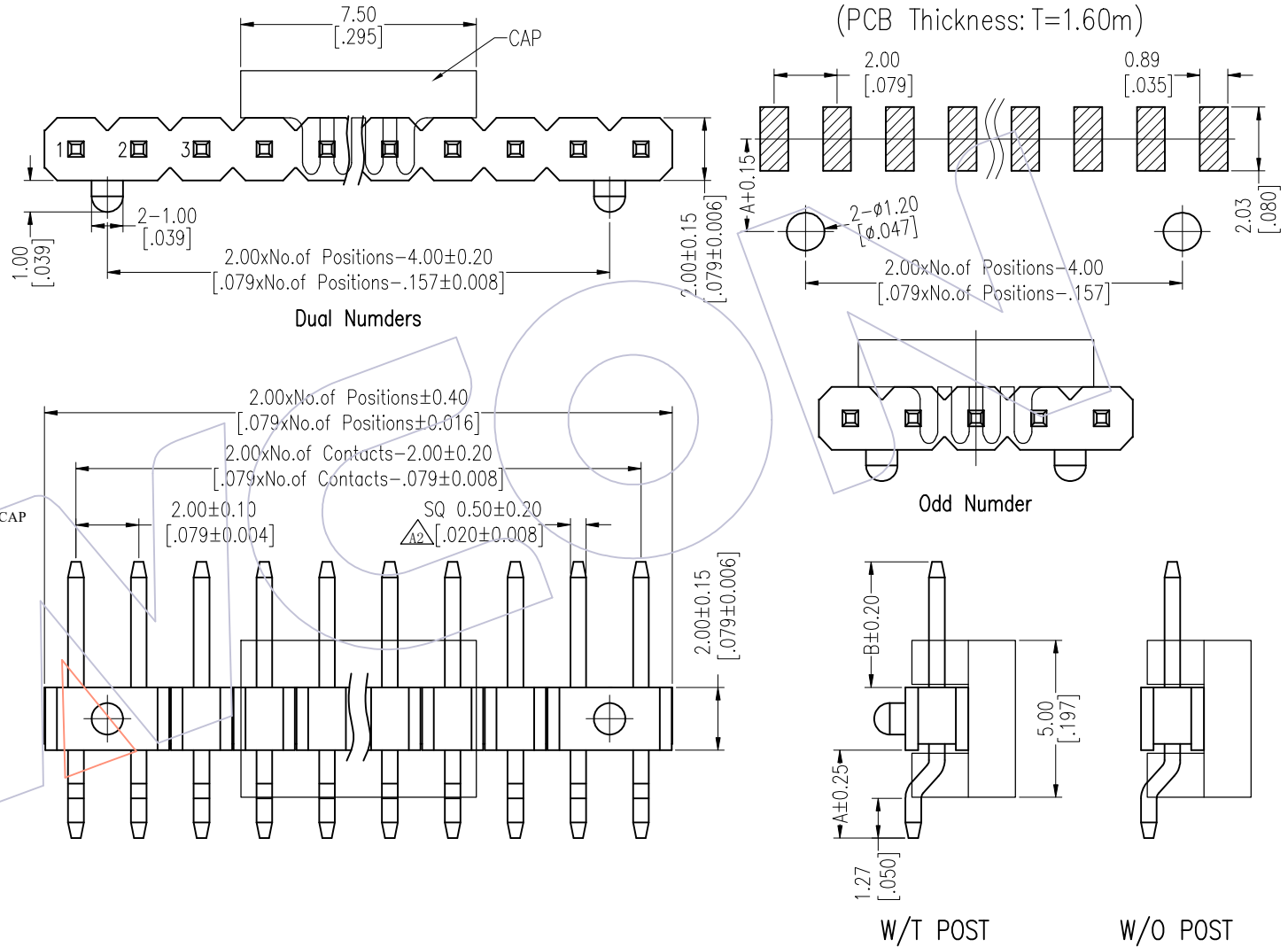

REV	DATE	MODIFICATION DESCRIPTION	CHANGE	OPERATION	DRAW	DATE	SCALE	Fit	PART NO.
A2	2025/04/09	Standardization Drawing	CP	x.X ± 0.40	CP	2025/04/09	UNIT	mm	1220-11XXXXXXCRXX $\Delta 1$
A1	2018/01/18	Modify P/N	Liu	x.xx ± 0.25	CHECK	2025/04/09	SIZE	A4	TITLE: PH2.00 SINGLE ROW 90° SMT H=2.0
AO	2012/04/26	NEW	William Chen	x.xxx ± 0.15	TANG	2025/04/09	SHEET	1/4	Customer NO.
				Angle $\pm 3'$	APPROVE	2025/04/09	PROJ.		
				DIM TOL	Steven Zhao				

WCON
 Http: www.wcon.com
 WCON-Dongguan WCON-Kunshan
 Tel: +86 769 85358920 Tel: +86 512 57468408
 Fax: +86 769 85358915 Fax: +86 512 57468468
 E-mail: sales@wcon.com E-mail: salesks@wcon.com

HSF

Packing:

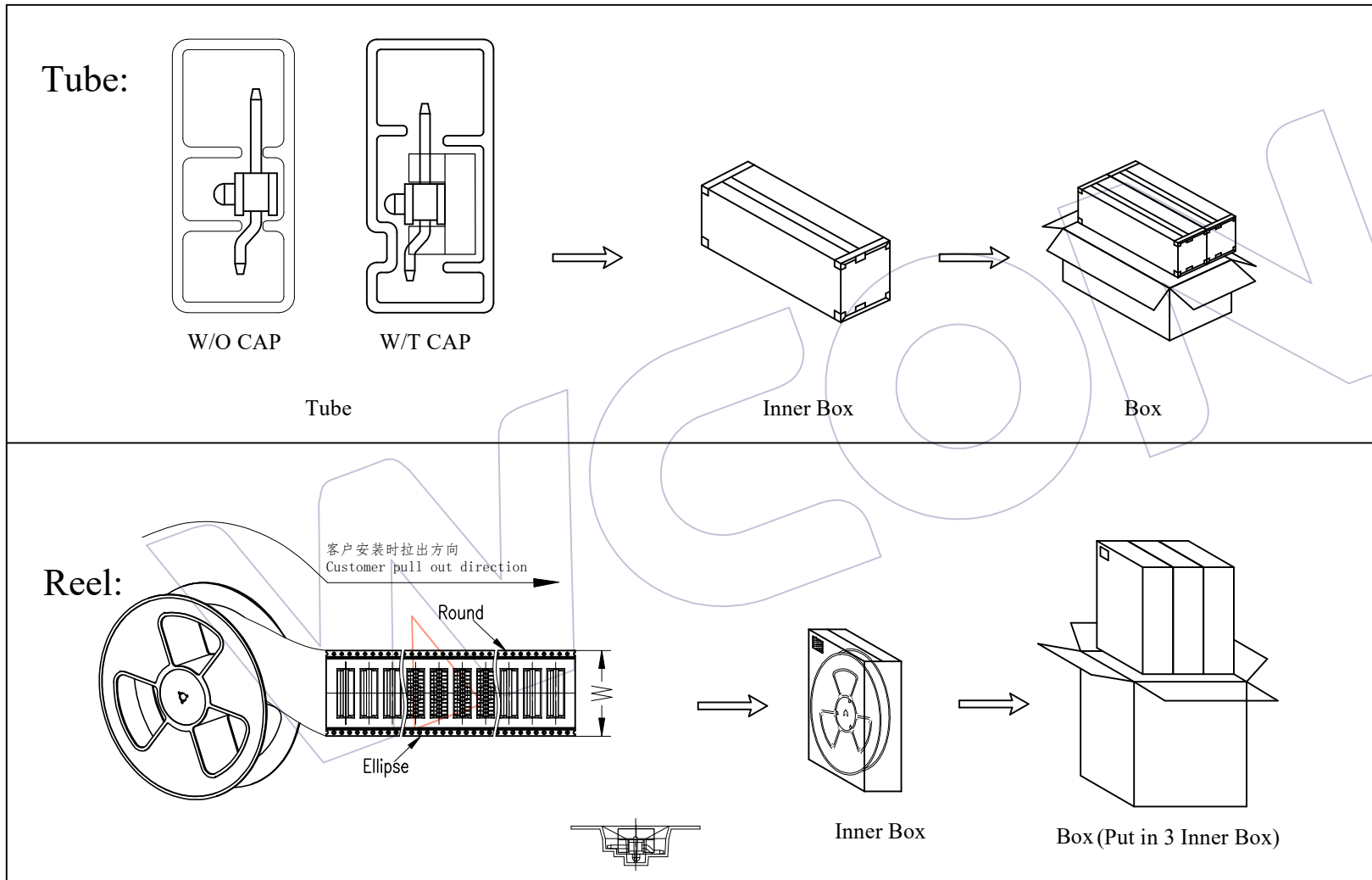

REV	DATE	MODIFICATION DESCRIPTION	CHANGE	OPERATION	DRAW	DATE	SCALE	Fit	PART NO.
A2	2025/04/09	Standardization Drawing	CP	x.X ±0.40	CP	2025/04/09	UNIT	mm	1220-11XXXXZXXCRXX
A1	2018/01/18	Modify P/N	Liu	x.XX ±0.25	CHECK	DATE	SIZE	A4	TITLE:
AO	2012/04/26	NEW	William Chen	x.XXX ±0.15	TANG	2025/04/09	SHEET	2/4	PH2.00 SINGLE ROW
				Angle ± 3'	APPROVE	DATE	PROJ.		90° SMT H=2.0
				DIM TOL	Steven Zhao	2025/04/09			Customer NO.

WCON
 Http: www.wcon.com
 WCON-Dongguan Tel: +86 769 85358920
 WCON-Kunshan Tel: +86 512 57468408
 Fax: +86 769 85358915 Fax: +86 512 57468468
 E-mail: sales@wcon.com E-mail: salesks@wcon.com

HSF

Packaging Quantity Refers To The Following Table

W/O CAP

PINS	Q'ty/Tube	Q'ty/Inner Box	Q'ty/Box
4	72	17,280	34,560
5	58	13,920	27,840
6	48	11,520	23,040
7	41	9,840	19,680
8	36	8,640	17,280
9	32	7,680	15,360
10	29	6,960	13,920
11	26	6,240	12,480
12	24	5,760	11,520
13	21	5,040	10,080
14	20	4,800	9,600
15	19	4,560	9,120
16	17	4,080	8,160
17	16	3,840	7,680
18	16	3,840	7,680
19	15	3,600	7,200
20	14	3,360	6,720
21	13	3,120	6,240
22	13	3,120	6,240

W/O CAP



PINS	Q'ty/Tube	Q'ty/Inner Box	Q'ty/Box
23	12	2,880	5,760
24	11	2,640	5,280
25	11	2,640	5,280
26	11	2,640	5,280
27	10	2,400	4,800
28	10	2,400	4,800
29	9	2,160	4,320
30	9	2,160	4,320
31	9	2,160	4,320
32	9	2,160	4,320
33	8	1,920	3,840
34	8	1,920	3,840
35	8	1,920	3,840
36	8	1,920	3,840
37	7	1,680	3,360
38	7	1,680	3,360
39	7	1,680	3,360
40	7	1,680	3,360

W/T CAP

PINS	Q'ty/Tube	Q'ty/Inner-Box	Q'ty/Box
4	72	8,640	17,280
5	58	6,960	13,920
6	48	5,760	11,520
7	41	4,920	9,840
8	36	4,320	8,640
9	32	3,840	7,680
10	29	3,480	6,960
11	26	3,120	6,240
12	24	2,880	5,760
13	21	2,520	5,040
14	20	2,400	4,800
15	19	2,280	4,560
16	17	2,040	4,080
17	16	1,920	3,840
18	16	1,920	3,840
19	15	1,800	3,600
20	14	1,680	3,360
21	13	1,560	3,120
22	13	1,560	3,120

W/T CAP

PINS	Q'ty/Tube	Q'ty/Inner Box	Q'ty/Box
23	12	1,440	2,880
24	11	1,320	2,640
25	11	1,320	2,640
26	11	1,320	2,640
27	10	1,200	2,400
28	10	1,200	2,400
29	9	1,080	2,160
30	9	1,080	2,160
31	9	1,080	2,160
32	9	1,080	2,160
33	8	960	1,920
34	8	960	1,920
35	8	960	1,920
36	8	960	1,920
37	7	840	1,680
38	7	840	1,680
39	7	840	1,680
40	7	840	1,680

REV	DATE	MODIFICATION DESCRIPTION	CHANGE	OPERATION	DRAW	DATE	SCALE	Fit	PART NO.	 Http: www.wcon.com WCON-Dongguan Tel: +86 769 85358920 WCON-Kunshan Tel: +86 512 57468408 Fax: +86 769 85358915 Fax: +86 512 57468468 E-mail: sales@wcon.com E-mail: salesks@wcon.com
A2	2025/04/09	Standardization Drawing	CP	x.x ±0.40	CP	2025/04/09	UNIT	mm	1220-11XXXXXXCRXX 	
A1	2018/01/18	Modify P/N	Liu	x.xx ±0.25	CHECK	DATE	SIZE	A4	TITLE:	
AO	2012/04/26	NEW	William Chen	x.xxx ±0.15	TANG	2025/04/09	SHEET	3/4	PH2.00 SINGLE ROW 90° SMT H=2.0	
				Angle ± 3'	APPROVE	DATE	PROJ.		Customer NO.	
				DIM TOL	Steven Zhao	2025/04/09				

HSF

Packaging Quantity Refers To The Following Table

B=2.5/3.0

B=2.5/3.0

B=3.5/4.0

B=3.5/4.0

PINS	W	Q'ty/Reel	Q'ty/Inner Box	Q'ty/Box	PINS	W	Q'ty/Reel	Q'ty/Inner Box	Q'ty/Box	PINS	W	Q'ty/Reel	Q'ty/Inner Box	Q'ty/Box	PINS	W	Q'ty/Reel	Q'ty/Inner Box	Q'ty/Box
2	16	1,000	4,000	12,000	19	56	1,000	1,000	3,000	2	16	750	3,000	9,000	19	56	750	750	2,250
3	16	1,000	4,000	12,000	20	56	1,000	1,000	3,000	3	16	750	3,000	9,000	20	56	750	750	2,250
4	24	1,000	3,000	9,000	21	56	1,000	1,000	3,000	4	24	750	2,250	6,750	21	56	750	750	2,250
5	24	1,000	3,000	9,000	22	56	1,000	1,000	3,000	5	24	750	2,250	6,750	22	56	750	750	2,250
6	24	1,000	3,000	9,000	23	72	1,000	1,000	3,000	6	24	750	2,250	6,750	23	72	750	750	2,250
7	24	1,000	3,000	9,000	24	72	1,000	1,000	3,000	7	24	750	2,250	6,750	24	72	750	750	2,250
8	32	1,000	2,000	6,000	25	72	1,000	1,000	3,000	8	32	750	1,500	4,500	25	72	750	750	2,250
9	32	1,000	2,000	6,000	26	72	1,000	1,000	3,000	9	32	750	1,500	4,500	26	72	750	750	2,250
10	32	1,000	2,000	6,000	27	72	1,000	1,000	3,000	10	32	750	1,500	4,500	27	72	750	750	2,250
11	44	1,000	2,000	6,000	28	72	1,000	1,000	3,000	11	44	750	1,500	4,500	28	72	750	750	2,250
12	44	1,000	2,000	6,000	29	72	1,000	1,000	3,000	12	44	750	1,500	4,500	29	72	750	750	2,250
13	44	1,000	2,000	6,000	30	72	1,000	1,000	3,000	13	44	750	1,500	4,500	30	72	750	750	2,250
14	44	1,000	2,000	6,000	31	88	1,000	1,000	3,000	14	44	750	1,500	4,500	31	88	750	750	2,250
15	44	1,000	2,000	6,000	32	88	1,000	1,000	3,000	15	44	750	1,500	4,500	32	88	750	750	2,250
16	44	1,000	2,000	6,000	33	88	1,000	1,000	3,000	16	44	750	1,500	4,500	33	88	750	750	2,250
17	56	1,000	1,000	3,000	34	88	1,000	1,000	3,000	17	56	750	750	2,250	34	88	750	750	2,250
18	56	1,000	1,000	3,000	35	88	1,000	1,000	3,000	18	56	750	750	2,250	35	88	750	750	2,250

				OPERATION	DRAW	DATE	SCALE	Fit	PART NO.	 Http: www.wcon.com WCON-Dongguan Tel: +86 769 85358920 Fax: +86 769 85358915 E-mail: sales@wcon.com WCON-Kunshan Tel: +86 512 57468408 Fax: +86 512 57468468 E-mail: salesks@wcon.com
A2	2025/04/09	Standardization Drawing	CP	x.X ±0.40	CP	2025/04/09	UNIT	mm	1220-11XXXXXXCRXX 	
A1	2018/01/18	Modify P/N	Liu	x.XX ±0.25	CHECK	DATE	SIZE	A4	TITLE:	
A0	2012/04/26	NEW	William Chen	x.XXX ±0.15	TANG	2025/04/09	SHEET	4/4	PH2.00 SINGLE ROW 90° SMT H=2.0	
REV	DATE	MODIFICATION DESCRIPTION	CHANGE	Angle ± 3'	APPROVE	DATE	PROJ.		Customer NO.	
				DIM TOL	Steven Zhao	2025/04/09				