

HSF

NOTES:

Current Rating: 10A
 Voltage Rating: 300V
 Contact Resistance: 8milliohm Max
 Withstand Voltage: AC2000V
 Insulation Resistance: 1000Megohm Min
 Screw Torque: 4.4 lbf.in
 Wire range: 12-30AWG $\triangle A_3$
 Operation Temperature: -40°C to +105°C
 2P With 1 RAMP Locking "A"

Ordering Information:

P F 508- C XX X SM N I N

F=Female Pitch No.of Pins Contact Plated Blank=W/T WCON Logo
 508=5.08 02-24P SM=Matte Tin N=W/O WCON Logo

Color Type
 A=Green N=W/O Two Side Screw
 Y=Yellow
 R=Red
 O=Orange
 U=Blue
 G=Grey(灰色429C)

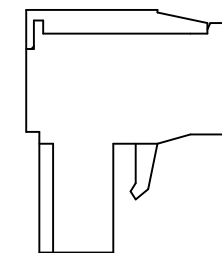

W/O WCON LOGO $\triangle A_5$

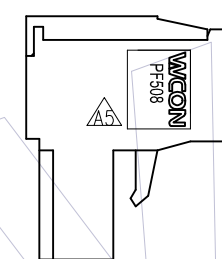
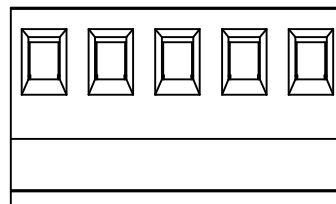

W/T WCON LOGO

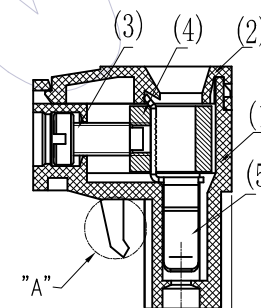
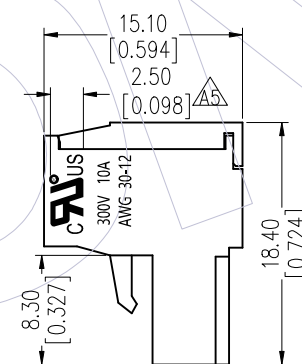
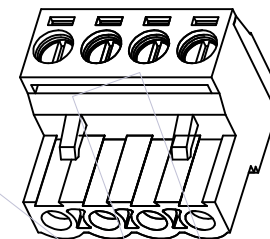
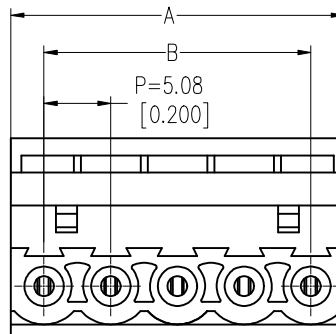
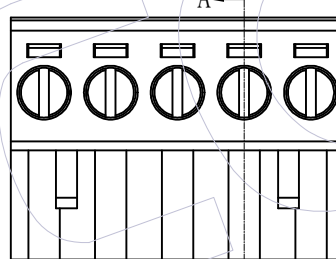

Section A-A

13P	66.04 ±0.30	60.96 ±0.30			
12P	60.96 ±0.30	55.88 ±0.30	24P	121.92 ±0.50	116.84 ±0.50
11P	55.88 ±0.30	50.80 ±0.30	23P	116.84 ±0.50	111.76 ±0.50
10P	50.80 ±0.30	45.72 ±0.30	22P	111.76 ±0.50	106.68 ±0.50
9P	45.72 ±0.30	40.64 ±0.30	21P	106.68 ±0.50	101.60 ±0.50
8P	40.64 ±0.30	35.56 ±0.30	20P	101.60 ±0.50	96.52 ±0.50
7P	35.56 ±0.20	30.48 ±0.20	19P	96.52 ±0.40	91.44 ±0.40
6P	30.48 ±0.20	25.40 ±0.20	18P	91.44 ±0.40	86.36 ±0.40
5P	25.40 ±0.20	20.32 ±0.20	17P	86.36 ±0.40	81.28 ±0.40
4P	20.32 ±0.20	15.24 ±0.20	16P	81.28 ±0.40	76.20 ±0.40
3P	15.24 ±0.20	10.16 ±0.20	15P	76.20 ±0.40	71.12 ±0.40
2P	10.16 ±0.20	5.08 ±0.10	14P	71.12 ±0.40	66.04 ±0.40
PIN	A	B	PIN	A	B

(5)	Contact	TPT051-PSM002	N	C5191R-H T=0.4mm
(4)	Pin Block	BL025-1SNI01	N	C3604
(3)	Screw	MA025-1SXX01	N	C1018
(2)	Cover	XPC508-XXB1XN1	1	PA66 UL94-V0
(1)	Housing	XPF508-XXB1XN1(N)	1	PA66 UL94-V0
ITEM	品名	料号	数量	材料

A5	2020/08/03	ADD LOGO; ADD W/O LOGO P/N $\triangle A_5$	XSR	OPERATION	DRAW	DATE	SCALE	FIT	PART NO.
A4	2018/09/12	PF508-CXXASMN1 → PF508-CXXXSMN1 $\triangle A_4$	XSR	X.X ±0.40	XSR	2020/08/03	UNIT	mm	PF508-CXXXSMN1(N) $\triangle A_1 \triangle A_4 \triangle A_5$
A3	2015/12/15	Modify $\triangle A_3$		X.XX ±0.25	CHECK	DATE	SIZE	A4	TITLE:
A0	2011/06/08	NEW		X.XXX ±0.15			SHEET	1/1	5.08mm Pitch Female Pluggable Terminal Blocks
REV	DATE	MODIFICATION DESCRIPTION	CHANGE	Angle ± 3° DIM TOL	APPROVE	DATE	PROJ.		Customer NO.

WCON

Http: www.wcon.com

WCON-Dongguan
 Tel: +86 769 85358920
 Fax: +86 769 85358915
 E-mail: sales@wcon.com

WCON-Kunshan
 Tel: +86 512 57468408
 Fax: +86 512 57468468
 E-mail: salesks@wcon.com