

NOTES: ⚠

Rated Current: 5-8A  
 Rated Voltage: 250V AC  
 Contact Resistance: 10mΩ Max.  
 Withstand Voltage: 1000V  
 Insulation Resistance: 5000MΩ Min.  
 Operation Temperature:  
 Tin Plating: -40℃ to +125℃  
 Gold Plating: -40℃ to +125℃

Contact Material: Copper Alloy  
 Contact Plating: Sn or Au over Ni  
 Main Body Material: PBT+30%GF White  
 Waterproof grade: IP68/IP69K(After installation)

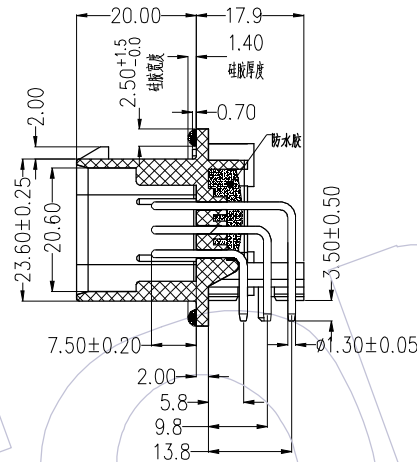
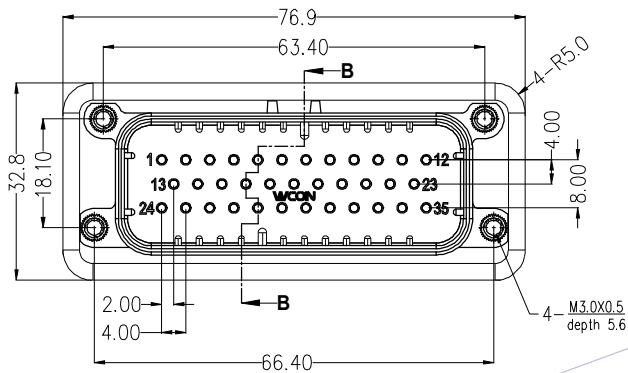

Recommended P.C.B Layout(Top Side)  
 (PCB BOARD TOLERANCE±0.05 T=1.50mm)

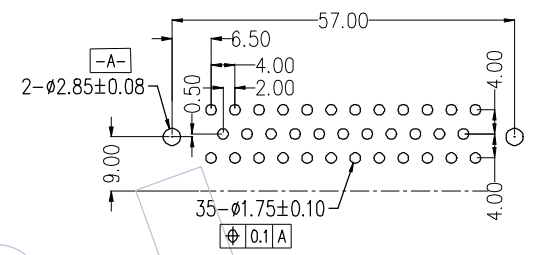

Ordering Information

74040-3MR 035 A B XX J A 2 W

Contact Material:  
 B=Brass  
 A=Tray  
 Body Material:  
 A=PBT  
 Contact Plating:  
 G0=1u" Gold  
 G3=10u" Gold  
 SN=Sn  
 SM=Matte Sn

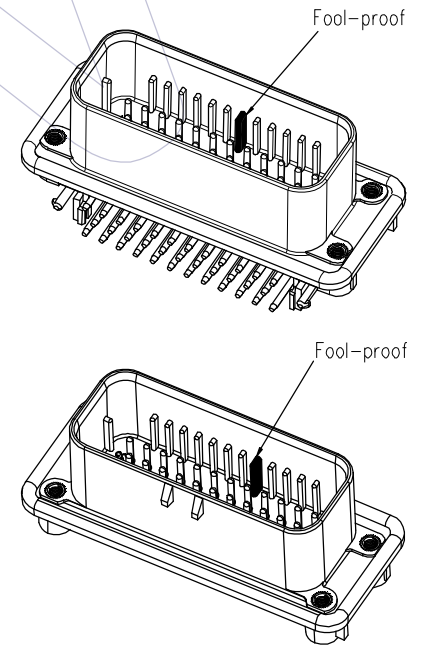
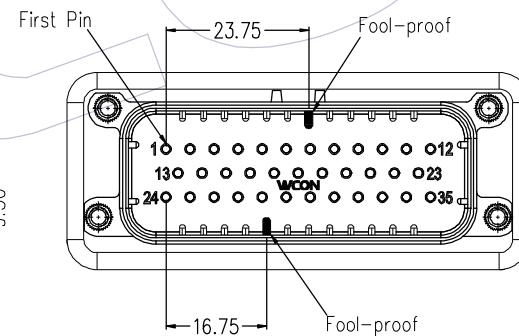
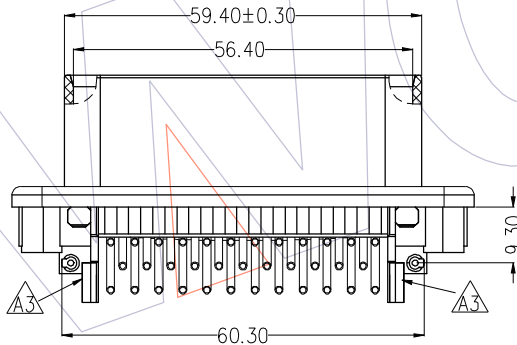

Fool-proof Structure

Matched Female Number
74040-3FC035AN00WA2W

A3	2022.06.08	Modify	OPERATION	DRAW	DATE	SCALE	1:1	PART NO. <b>74040-3MR035ABXXJA2W</b> ⚠
A2	2020.08.03	Modify	x.x ±0.40	XSR	2022.06.08	UNIT	mm	
A1	2019.04.16	Modify	x.xx ±0.25	CHECK	DATE	SIZE	A4	TITLE: 35P 90° Three row automobile waterproof connector (Upgraded Version)
A0	2018.11.09	NEW	x.xxx ±0.15	APPROVE	DATE	SHEET	1/2	
REV	DATE	MODIFICATION DESCRIPTION	CHANGE	DIM	TOL	PROJ.	Customer NO.	

**WCON**

Http: www.wcon.com

WCON-Dongguan Tel: +86 769 85358920  
 WCON-Kunshan Tel: +86 512 57468408  
 Fax: +86 769 85358915  
 Fax: +86 512 57468468  
 E-mail: sales@wcon.com  
 E-mail: salesks@wcon.com

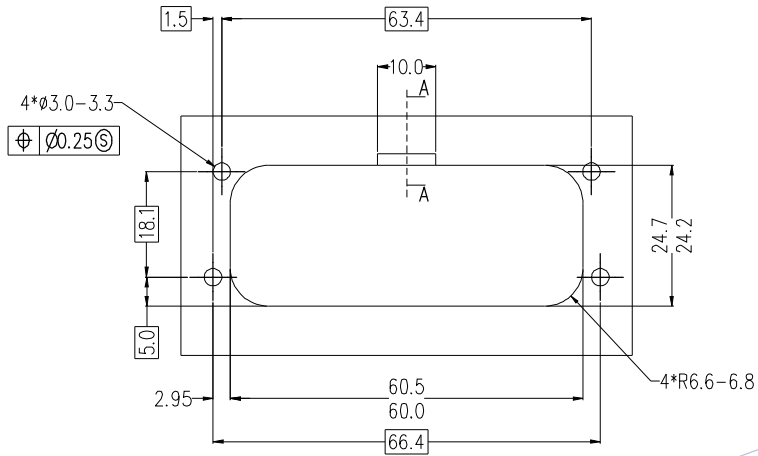

RECOMMENDED MOUNTING HOLE LAYOUT FOR 5.0 MAX THICK PANEL (35PIN)

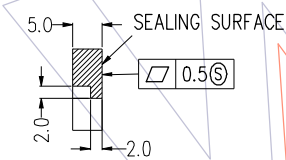

OPTIONAL CONSTRUCTION IF PANEL THICKNESS IS GREATER THAN 2.0

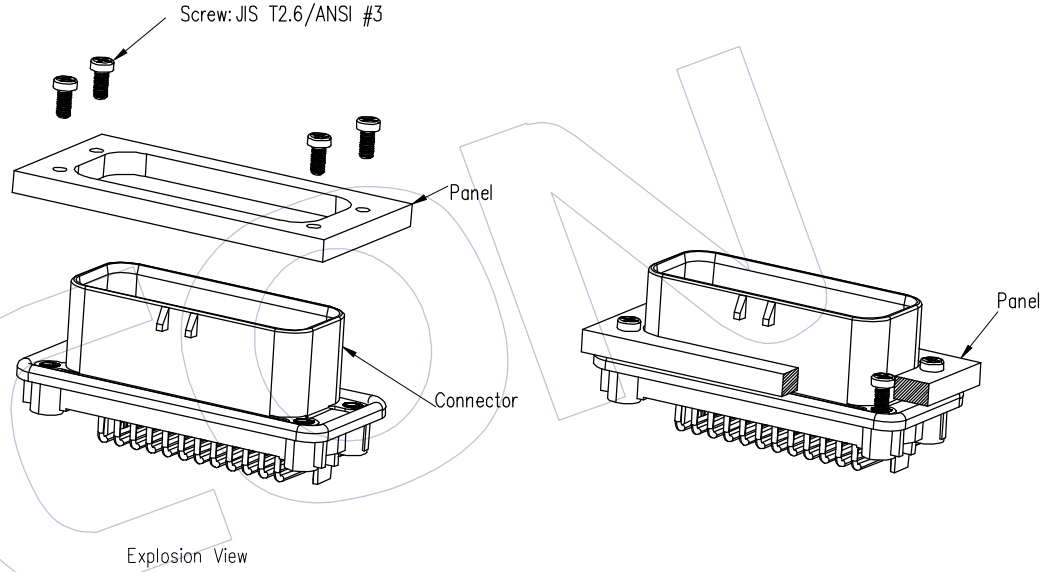

Explosion View

A3	2022.06.08	Modify	—	OPERATION		DRAW	DATE	SCALE	1:1	PART NO.		 Http: www.wcon.com WCON-Dongguan Tel: +86 769 85358920 WCON-Kunshan Tel: +86 512 57468408 Fax: +86 769 85358915 Fax: +86 512 57468468 E-mail: sales@wcon.com E-mail: salesks@wcon.com
A2	2020.08.03	Modify	—	x.x	±0.40	XSR	2022.06.08	UNIT	mm	TITLE: 35P 90° Three row automobile waterproof connector (Upgraded Version)		
A1	2019.04.16	Modify	—	x.xx	±0.25	CHECK	DATE	SIZE	A4	Customer NO.		
A0	2018.11.09	NEW	—	x.xxx	±0.15	APPROVE	DATE	SHEET	2/2			
REV	DATE	MODIFICATION DESCRIPTION	CHANGE	Angle	± 3°			PROJ.	☉			
				DIM	TOL							